

20 JUN 1996

Ref: 96-F-0961

Dr. A. Victorian
P.O. Box 99
West PDO
Nottingham, NG8 3NT
ENGLAND

Dear Dr. Victorian:

This letter responds to your May 1, 1996, Freedom of Information Act (FOIA) request to the Advanced Research Project Agency which was received in this Directorate on May 8, 1996.

The enclosed document is provided as responsive to your request. There are no chargeable costs for processing your FOIA request in this instance.

Sincerely,

Signed

A. H. Passarella
Director
Freedom of Information
and Security Review

Enclosure:
As stated

Prepared by VOORHIES:gjv:6/19/96:DFOI:gr~~g~~pk_y1_wh

RR
PIS
✓

#8/5

~~CONFIDENTIAL~~

TECHNICAL REPORT
distributed by

UNCLASSIFIED

DTIC



DEFENSE TECHNICAL INFORMATION CENTER
8725 JOHN J. KINGMAN ROAD
SUITE 0944
FT. BELVOIR, VA 22060-6218

96-F-0961
#1815

~~CONFIDENTIAL~~

UNCLASSIFIED

UNCLASSIFIED

~~CONFIDENTIAL~~

Policy on the Redistribution of DTIC-Supplied Information

As a condition for obtaining DTIC services, all information received from DTIC that is not clearly marked for public release will be used only to bid or perform work under a U.S. Government contract or grant or for purposes specifically authorized by the U.S. Government agency that is sponsoring access. Further, the information will not be published for profit or in any manner offered for sale.

Non-compliance may result in termination of access and a requirement to return all information obtained from DTIC.

NOTICE

We are pleased to supply this document in response to your request.

The acquisition of technical reports, notes, memorandums, etc., is an active, ongoing program at the **Defense Technical Information Center (DTIC)** that depends, in part, on the efforts and interest of users and contributors.

Therefore, if you know of the existence of any significant reports, etc., that are not in the **DTIC** collection, we would appreciate receiving copies or information related to their sources and availability.

The appropriate regulations are Department of Defense Directive 3200.12, DoD Scientific and Technical Information Program; Department of Defense Directive 5230.24, Distribution Statements on Technical Documents; National Information Standards Organization (NISO) Standard Z39.18-1995, Scientific and Technical Reports - Elements, Organization and Design; Department of Defense 5200.1-R, Information Security Program Regulation.

Our **Programs Management Branch, DTIC-OCP**, will assist in resolving any questions you may have concerning documents to be submitted. Telephone numbers for that office are (703) 767-8040, or DSN 427-8040. The **Reference and Retrieval Division, DTIC-BR**, will assist in document identification, ordering and related questions. Telephone numbers for that office are (703) 767-8274 or DSN 427-8274.

**DO NOT RETURN THIS DOCUMENT TO DTIC
EACH ACTIVITY IS RESPONSIBLE FOR DESTRUCTION OF THIS
DOCUMENT ACCORDING TO APPLICABLE REGULATIONS.**

UNCLASSIFIED

~~CONFIDENTIAL~~



UNAN

~~76-5724~~

7

**RESEARCH
ANALYSIS
CORPORATION**

ADC 951256

DEFENSE ADVANCED RESEARCH
PROJECTS AGENCY, S&IO

**Non-Lethal Incapacitating Weapon:
Liquid Stream Projector Feasibility Study (U)**

Distribution Limited to U. S. Government

5 JAN

DTIC
ELECTRONIC
S JAN 5 1982 D
A

DTIC FILE COPY

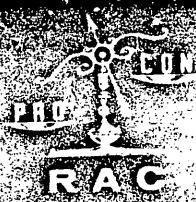

~~UNCLASSIFIED~~

~~CONFIDENTIAL~~

The contents of this publication represents the views of the Advanced Technology Division, RAC and should not be considered as having official RAC approval or ARPA approval until reviewed and evaluated by those agencies and subsequently endorsed.

This document contains information affecting the national defense of the United States within the meaning of the Espionage Laws, Title 18, U. S. C., Sections 793 and 794. The transmission or the revelation of its contents in any manner to an unauthorized person is prohibited by law.

~~CONFIDENTIAL~~

~~UNCLASSIFIED~~

~~CONFIDENTIAL~~

~~UNCLASSIFIED~~

JUN 11 1996

DOWNGRADED TO UNCLASSIFIED
PER AUTHORITY OF THE DIRECTOR,
DEFENSE ADVANCED RESEARCH
PROJECTS AGENCY, S&IO

ADVANCED TECHNOLOGY DIVISION
TECHNICAL PAPER RAC-TP-168
Published March 1965

Non-Lethal Incapacitating Weapon: Liquid Stream Projector Feasibility Study

by
John M. Breit

DTIC
SELECTED
S JAN 5 1982 D
A

SD-212
AO 15-81

"NATIONAL SECURITY INFORMATION"

"Unauthorized Disclosure Subject to Criminal
Sanctions"



RESEARCH ANALYSIS CORPORATION

MCLEAN, VIRGINIA

~~CONFIDENTIAL~~

302750

~~UNCLASSIFIED~~

~~UNCLASSIFIED~~

~~CONFIDENTIAL~~

Received for Publication 17 March 1965
Published March 1965
by
RESEARCH ANALYSIS CORPORATION
McLean, Virginia

~~CONFIDENTIAL~~

~~UNCLASSIFIED~~

~~CONFIDENTIAL~~

UNCLASSIFIED

FOREWORD

ARPA requested RAC assistance in a preliminary investigation to determine feasibility of a system to incapacitate a person temporarily with a liquid material. The liquid should be projected as a stream to a minimum range of thirty (30) feet with sufficient accuracy to avoid affecting other persons close by. The liquid stream projector should be small and lightweight so as to be carried by an individual and should present no hazard to the operator. ARPA subsequently passed the problem to RAC under Contract SD-212.

This paper addresses itself to the basic feasibility investigation.

George A. Martinez
Chief, Advanced Technology
Division

Accession For	
NTIS GRA&I	<input type="checkbox"/>
DTIC TAB	<input type="checkbox"/>
Unannounced	<input checked="" type="checkbox"/>
Justification	
By _____	
Distribution/	
Availability Codes	
Part	Avail and/or Special
B	

~~CONFIDENTIAL~~

UNCLASSIFIED

UNCLASSIFIED

CONFIDENTIAL

ACKNOWLEDGMENTS

The principal technical investigations for this paper concerning the projection and material to be projected were performed by Alexandria Division, American Machine and Foundry Company, Alexandria, Virginia. Investigation of a suitable nozzle was performed by Bowles Engineering Corporation, Silver Spring, Maryland. The laboratory and use testing was performed by the U. S. Army Chemical Research and Development Laboratories, Edgewood Arsenal, Maryland.

CONFIDENTIAL

UNCLASSIFIED

~~CONFIDENTIAL~~

UNCLASSIFIED

AGENT

In an attempt to assemble rapidly a list of liquid agents with appropriate characteristics, a number of persons and groups were contacted. These people were all known to have some related interest in disabling materials. Visits were made to Army installations at Fort Detrick and Edgewood, Maryland. Because they had recently purchased large quantities of an animal repellent, the Post Office Department was called and they suggested contacting Animal Repellants, Inc., of Griffin, Georgia, the supplier of the Department's material. Finally, a highly instructive discussion took place with Dr. Ronald Spenser of the Department of Agriculture.

Table I summarizes, qualitatively, the essential results of these contacts. It lists the materials which were most prominently mentioned by the various experts and tabulates the characteristics of each material in terms of the relevant parameters.

The material bought by the Post Office Department for use against dogs is a 15 percent solution of capsicum oleoresin in a vehicle of light mineral oil. Capsicum is a derivative of red pepper. This material is available in 7.5 and 15 percent strengths from Animal Repellants, Inc., and is sold in an aerosol-can dispenser.

It is possible to obtain capsicum in tincture form commercially. For tests to be described, the alcohol was substantially boiled off and the remaining material dissolved in water. The interest in a water-based agent is established in the later discussion on nozzles.

Ammonia is known to be an irritating material and is included because it was the substance most frequently suggested.

It was contended that a volatile liquid, if projected against the skin or eyes of a person, would produce a painful or otherwise disabling effect. This type of liquid is included in Table I in spite of the restriction against highly diffusing materials because the information was readily available and judged useful for completeness.

To substantiate the characteristics of the various materials as reported by the several experts, a series of tests were conducted at the facilities of the Army Chemical Center, Edgewood, Maryland. One series of tests was designed to establish medical consequences and another to verify the effectiveness as a disabling material. A detailed summary of the Edgewood tests is at

~~CONFIDENTIAL~~

UNCLASSIFIED

UNCLASSIFIED

CONFIDENTIAL

COMPARISON CHART ON AGENTS

	Effectiveness	Speed of Response	Permanent Damage	Effective Time	Volatility	Half Life	Effect of Temperature	Relative Range
Capsicum in Mineral Oil	High	Very fast	None	Minutes	Very low	Indefinite	Much	Moderate
Capsicum in Water	High	Very fast	None	Minutes	Very low	Indefinite	Very little	Long
CS Solution	Poor	Very fast	Possible	Minutes	High	Unknown	Unknown	Long
Ammonia Solution	Fair	Very fast	Possible	Minutes	Low	Indefinite	Very little	Long
Volatile Liquids	Poor	Very fast	Possible	Seconds	Very high	Indefinite	Much	Short

TABLE I

CONFIDENTIAL

UNCLASSIFIED

~~CONFIDENTIAL~~

UNCLASSIFIED

CONTENTS

PREFACE	111
ACKNOWLEDGMENT	iv
INTRODUCTION	1
SUMMARY	2
AGENT	3
WEAPON	7
Gun-Nozzle	
APPENDIXES	
Appendix A - Description of Laboratory Use Testing	18
Materials - Laboratory Testing - Use Testing	
Appendix B - Fluid Dynamics of Projecting a Jet of Liquid	23
Introduction - Internal Fluid Transfer - The Nozzle -	
Jet Interruption - Jet Stability	

~~CONFIDENTIAL~~

UNCLASSIFIED

UNCLASSIFIED

CONFIDENTIAL

**Non-Lethal Incapacitating Weapon:
Liquid Stream Projector Feasibility Study**

CONFIDENTIAL

UNCLASSIFIED

~~CONFIDENTIAL~~

UNCLASSIFIED

WEAPON

GUN

The initial phase of this project centered on obtaining information on available fluid projectors. To this end, a variety of toy water pistols was purchased and a patent search was conducted. The patents revealed no significant changes or additions to what could be learned from commercially available pistols. Some designs were uncovered dealing with pistols designed as fire extinguishers, but these did not differ in any fundamental way from the toys.

The water pistols were used with both water and light mineral oil and the effective range and shot dispersion for each pistol-liquid combination was established. The maximum effective ranges achieved were about 20 feet and, at that distance, the liquid stream was dispersed well beyond the limit of 12 inches. On the basis of these tests, it was determined that ordinary water pistols are not acceptable weapons.

The next attempt involved modified commercial CO₂ pistols which are made to fire a .22 caliber slug. Four such weapons were purchased and their operating principles analyzed. Two of the guns were modified so that the expanding gas would drive a piston, in turn expelling the liquid through a commercial nozzle. Tested in the same way as the toy pistols, the CO₂ devices showed relatively improved performance but the stream characteristics were poor in both range and dispersion. The most significant conclusion drawn from tests with the CO₂ pistols was that the nozzle would require careful design if the desired range and dispersion were to be achieved. It was recognized that an experimental apparatus was required with which the various operating parameters (pressure, liquid variables, nozzle configuration, etc.) could be separated.

A high pressure canister was constructed so that it could be filled with the test liquid and it included a standard fitting on to which various nozzles could be attached. The canister was connected to a tank of dry nitrogen at high pressure. Valving was accomplished by means of a long-handled, large-aperture switch on the gas line. Straight tube nozzles varying in diameter and length were tested with this apparatus. Also tested was a short contoured nozzle suggested by a consultant in fluid dynamics from Bowles Engineering Corporation, Silver Spring, Maryland. As predicted by this consultant, it was essential that the exit face of the nozzles be extremely flat, square, and have a sharp burr-free

~~CONFIDENTIAL~~

UNCLASSIFIED

UNCLASSIFIED

~~CONFIDENTIAL~~

edge. Best results were obtained with a tube 1/8 inch i.d. and six inches long. With this nozzle and a canister pressure of about 450 psi, the maximum range obtained was 40 feet. However, a very heavy mist appeared extending several feet to the side of the stream.

Experimentation with the high pressure canister produced two very useful pieces of information. Figure 1 shows an effect predicted by the Bowles consultant. Note that the effective range goes through a maximum as a function of canister pressure. This point of diminishing returns, therefore, sets an upper limit on the useful pressures. Figure 2 illustrates clearly the argument previously mentioned in the discussion of capsicum in mineral oil versus capsicum in water. Note that throughout the useful pressure range the water trajectory is significantly flatter than that for mineral oil. It is this difference which suggests a strong preference for the water-based agent.

These results indicated the advisability of undertaking two separate feasibility tasks, one relating to the design of a gun and the other involving optimization of nozzle performance.

Figure 3 is an assembly drawing of a gun designed to illustrate certain operating principles and is not intended to represent a prototype or final model. Figure 4 is a photograph of the same gun. The reservoir in this weapon has a volume of 160 cubic centimeters. Expanding gas is used as the source of projection energy. The gun can be charged either by puncturing a loaded CO₂ cartridge or by filling from a high pressure source such as a tank of dry nitrogen. Valving is accomplished by pulling the trigger which is linked to the nozzle tube. A hole in the nozzle tube is thereby aligned with the exit port of the reservoir. The nozzle tube returns to its closed position by the action of a spring on which the compression can be biased to achieve variable burst lengths

The principal results of experimentation with this gun are that an in-line mechanical action is shown to be desirable and that a valving action involving sliding through O-ring seals is technically sound. A prototype can now be constructed incorporating these techniques but with greatly reduced size and weight.

~~CONFIDENTIAL~~

UNCLASSIFIED

~~CONFIDENTIAL~~

UNCLASSIFIED

INTRODUCTION

This report summarizes a project, the objective of which was to establish the feasibility of disabling an individual momentarily at distances up to 30 feet by projecting a liquid stream of incapacitating material. The action of the liquid should be very rapid and highly effective in disabling a person, the effects should be fully reversible within a reasonable amount of time, but the reaction should last at least ten seconds. This latter requirement is based on the assumption that other methods of control can be carried out within a period of ten seconds. Because the operator of the weapon will not be protected against the effects of the liquid, the material should have a minimal tendency to diffuse. The projection weapon should be sufficiently small and lightweight so as to be easily carried by the operator, and aiming aids should be simple and accurate. Sufficient liquid should be carried to permit at least five shots (bursts) and the weapon should not leak liquid at any time, even after firing. The weapon and the liquid should remain operable for a period of one month without maintenance and the performance of the system should remain constant at temperatures from 0°F to 100°F. Stream dispersion at the maximum range should be about 12 inches in diameter.

Formal reliability analysis is not treated in this paper but will be given prime consideration when the fabrication of a prototype is undertaken. In the present context, the requirement for high reliability is a prime criterion in the selection of alternatives.

This paper treats separately the subjects of the disabling liquid and the weapon. The discussion of the weapon is further divided into a section relating to the housing and valving mechanisms (hereafter referred to as the gun) and another section dealing with nozzles.

~~CONFIDENTIAL~~

UNCLASSIFIED

UNCLASSIFIED

~~**CONFIDENTIAL**~~

SUMMARY

This investigation was conducted to establish the feasibility of projecting to a distance of at least 30 feet a liquid material which would, on contact, incapacitate a human momentarily. Of the various materials studied, capsicum oleoresin, a derivative of red pepper, was judged to have the characteristics desired. A gun was designed and fabricated to demonstrate the essential features necessary for properly housing and valving the liquid agent. A nozzle has been achieved which permits projection of the liquid to ranges as great as 40 feet with a dispersion of about 12 inches in diameter. With this nozzle misting is minimized. Further effort will be required to combine these elements into a prototype model.

~~**CONFIDENTIAL**~~

UNCLASSIFIED

UNCLASSIFIED

~~CONFIDENTIAL~~

Appendix A. A brief summary follows.

Five agents were used in both series of tests:

1. 15% Capsicum Oleoresin, 85% Mineral Oil.
2. 7.5% Capsicum Oleoresin, 92.5% Mineral Oil.
3. 100% Light Mineral Oil (for control).
4. 50 Volume Percent Ammonia Solution, 50 Volume Percent Water, plus one (1) milliliter Water Softener.
5. Capsicum Tincture concentrated to approximately 15% Capsicum, 85% Alcohol-Water Mixture, plus one (1) milliliter Water Softener.

The medical tests involved pouring measured amounts of the agents into the eyes and mouths of dogs. No permanent or severely injurious damage was produced by any of the substances. Although it is reported that cases of distemper developed, there is no clear causal relationship established. Furthermore, forcing the liquids down the throats of the animals is a gross exaggeration of what is likely to occur with humans.

Effectiveness tests consisted of spraying the faces of dogs previously selected for their bad dispositions. In addition to observers from AMF and RAC, the tests were recorded on color motion pictures. This film is on file at Edgewood and is classified CONFIDENTIAL. The various agents produced results consistent with the characteristics reported by the experts. The Edgewood report indicates that agent No. 5 did not seem to deter the animals as effectively as agents No. 1 and No. 2. These results are subjectively observed and are in contradiction with the view of the AMF and RAC observers. The animals were confined in relatively small pens and could not retreat very far. Therefore, the differences in reaction to the various agents were more subtle than they would have been if the dogs had more freedom in selecting a means of defense. For the purposes of this report it is concluded that agent No. 5 did not differ significantly in effectiveness from agents No. 1 or No. 2.

Capsicum in either mineral oil or water is seen, in Table I, to be very nearly ideal for the intended purpose. The principal limitation is that this substance must reach the eyes in order to produce maximum effects; the nose and mouth are affected to a

~~CONFIDENTIAL~~

UNCLASSIFIED

UNCLASSIFIED

~~CONFIDENTIAL~~

limited extent. However, when the eyes are subjected to capsicum the subject is almost immediately (i.e., in less than one second) preoccupied with a severe burning sensation and great difficulty in seeing. These effects last for several minutes (typically three to four minutes), after which all discomfort disappears. A few hours later it is virtually impossible for a doctor to detect any remaining irritation.

The two parameters for which the oil and the water vehicles differ are temperature and relative range. Mineral oil becomes more viscous with decreasing temperature, thereby inhibiting projection of this material. The difference in relative range is a result of differences in density and viscosity and will be described more fully later.

CS is a substance similar to tear gas and is usually used in its aerosol form. It is possible to produce CS solutions, but these are reported to have reduced effectiveness. Personnel at Fort Detrick warned that CS may be fatal or damaging to certain infants and predisposed or elderly people.

The principal objection to ammonia solutions is that they produce serious injury with sufficient frequency to be inappropriate in the present context.

Dr. R. Spenser of the Department of Agriculture has done considerable testing with volatile liquids for animal control and reports that these agents are ineffective at more than about eight feet, probably do nothing beside frighten the subject, and are not likely to affect humans in any way. At very short ranges permanent eye damage is a possibility.

Based on these considerations it has been concluded that capsicum is the most likely candidate for use as a disabling liquid. The choice between a mineral oil and water base should be made primarily on the ground weapon requirements. It also remains as a problem in weapon design to maximize the probability of delivering the agent to the eyes.

~~CONFIDENTIAL~~

UNCLASSIFIED

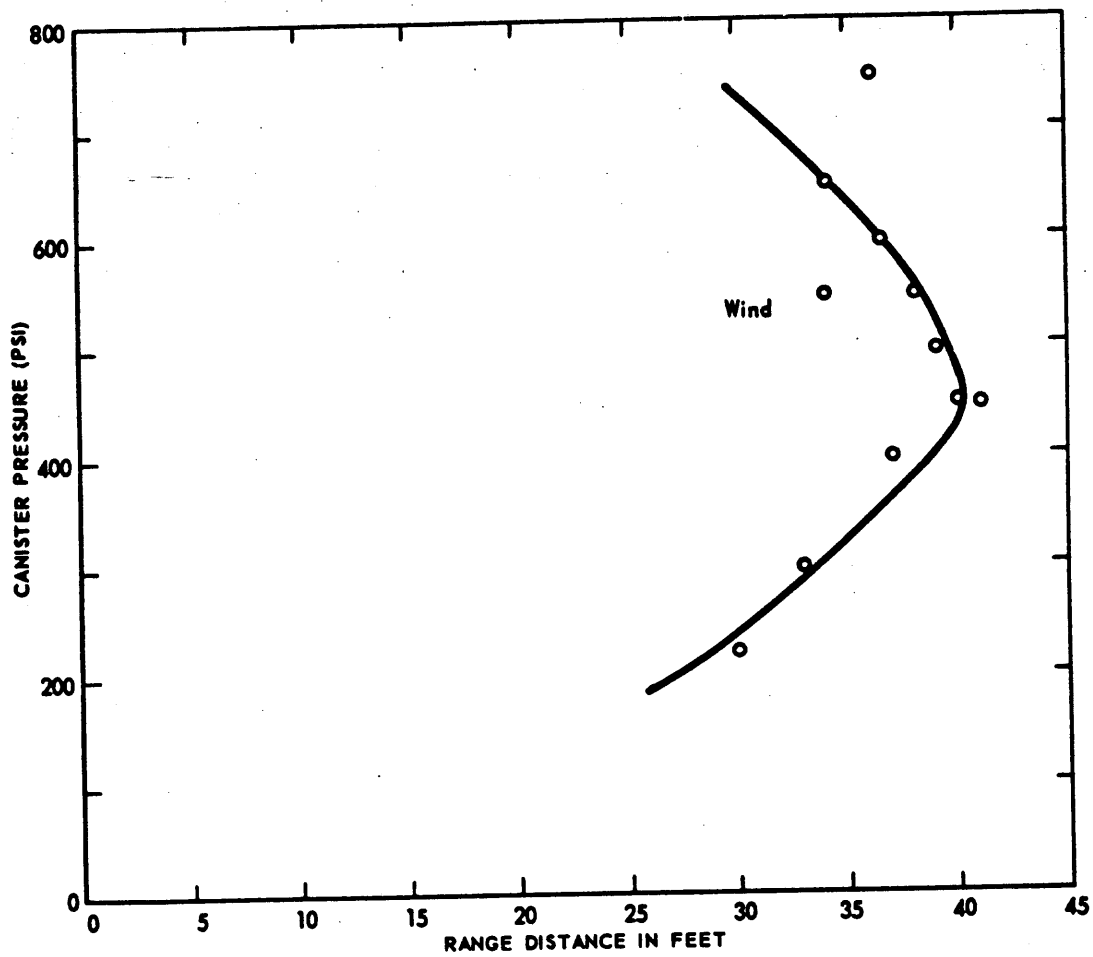

Fig. 1—Relationship of Pressure and Distance for Maximum Range
Canister 2A
1/8" Nozzle - 6" Long

UNCLASSIFIED

CONFIDENTIAL

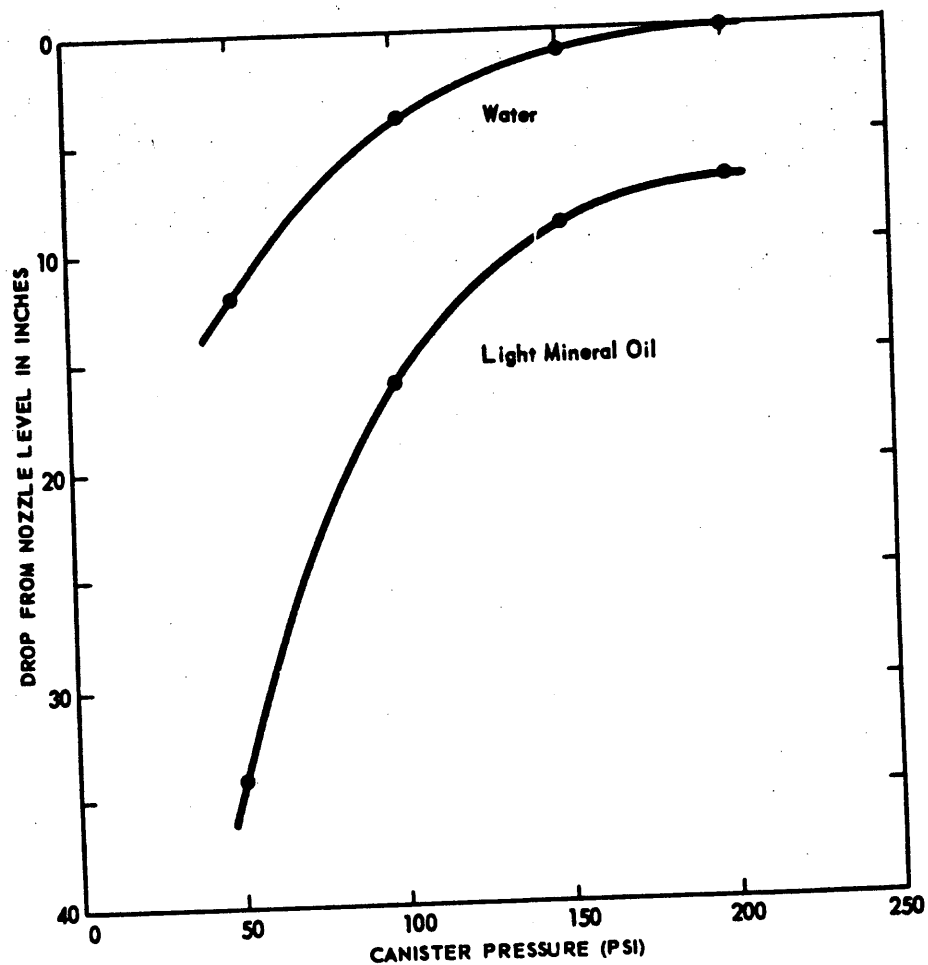

Fig. 2—Drop in Trajectory as a Function of Pressure for Liquids of Different Viscosities at 13' 8" from Nozzle

CONFIDENTIAL

UNCLASSIFIED

~~CONFIDENTIAL~~

UNCLASSIFIED

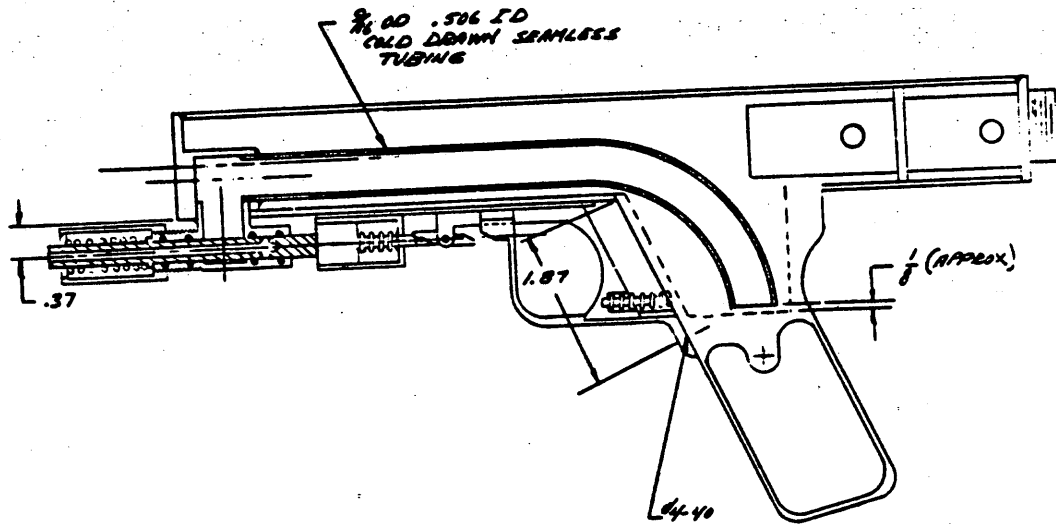

Fig. 3—Assembly Drawing of Feasibility Gun

~~CONFIDENTIAL~~

UNCLASSIFIED

UNCLASSIFIED

~~CONFIDENTIAL~~



Fig. 4—Photograph of Feasibility Gun

~~CONFIDENTIAL~~

UNCLASSIFIED

~~CONFIDENTIAL~~

UNCLASSIFIED

NOZZLE

There were indications that significant improvement in stream characteristics could be achieved by a more detailed analysis and design of the nozzle. Consequently, a subcontract was let to the Bowles Engineering Corporation, Silver, Spring, Maryland, a company specializing in fluid dynamics. A detailed summary of their work is at Appendix B. A brief summary of the work conducted and results obtained by Bowles follows.

The stream characteristics which are the object of this endeavor involve a smooth, uniform, coherent flow. Lacking these qualities a stream tends to break into droplets which experience increased air resistance and therefore cannot be projected to maximum ranges. Break-up of the stream also results in transverse velocities causing misting.

There exist several theoretical treatments of fluid flow through reducing sections. These theories were reviewed and their applicability to the present problem established, resulting in a nozzle profile as illustrated in Figure 5. The reason for using this contour is to achieve a uniform flow with a minimum of transverse velocity. The nozzle used in the experiments to be described was fabricated with this contour. It is a stringent requirement that the surface of the nozzle be extremely smooth and great care has been exercised to satisfy this requirement.

A stream will tend to break up if there exist vortex motions or if there are centers of turbulence. In order to straighten the flow (i.e., to eliminate vortices) vanes in the form of parallel tubes fill an approach section to the nozzle. Centers of turbulence are eliminated by preceding the nozzle with a series of screens selected for optimum mesh and minimum solidity. An experimental apparatus was constructed using a double-reduction nozzle preceded by straightening vanes and screens. Figure 6 is a diagram of this device inserted in a high pressure pipe. A photograph of the experimental apparatus is shown in Figure 7. For comparison purposes, a 1/8 inch i.d. tube six inches in length was attached to the same system. This tubular nozzle was one which produced best results in the earlier experimentation with the high pressure canister. Tests with this assembly consistently showed that the new nozzle achieved a 30 to 50 percent improvement in range and a significant decrease in misting. Observations were made at pressures up to about 500 psi. High speed photographs of the streams from the two nozzles appear in Appendix B.

~~CONFIDENTIAL~~

UNCLASSIFIED

~~CONFIDENTIAL~~

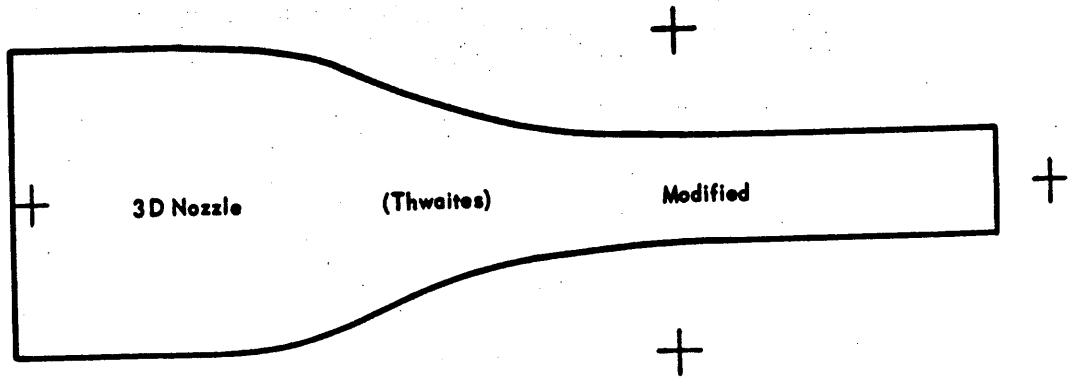

Fig. 5—Nozzle Profile

~~CONFIDENTIAL~~

~~UNCLASSIFIED~~

~~CONFIDENTIAL~~

UNCLASSIFIED

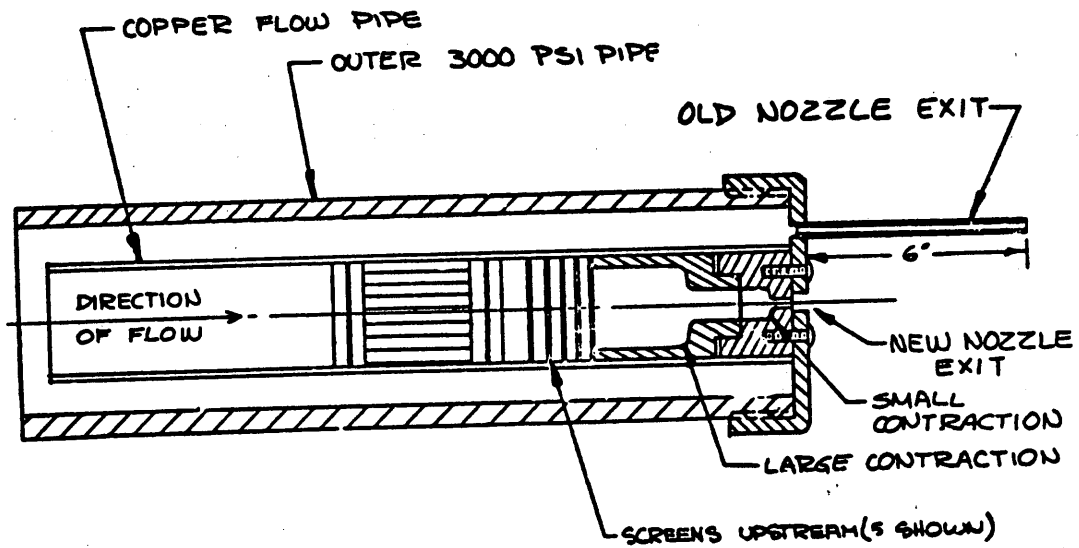

PISTOL ASSEMBLY WITH ONE SET OF
STRAIGHTENING TUBES AND 2 SPACING SCREENS

Fig. 6—Experimental Nozzle Apparatus
Pistol Assembly With One Set of Straightening
Tubes and 2 Spacing Screens.

~~CONFIDENTIAL~~

UNCLASSIFIED

~~CONFIDENTIAL~~

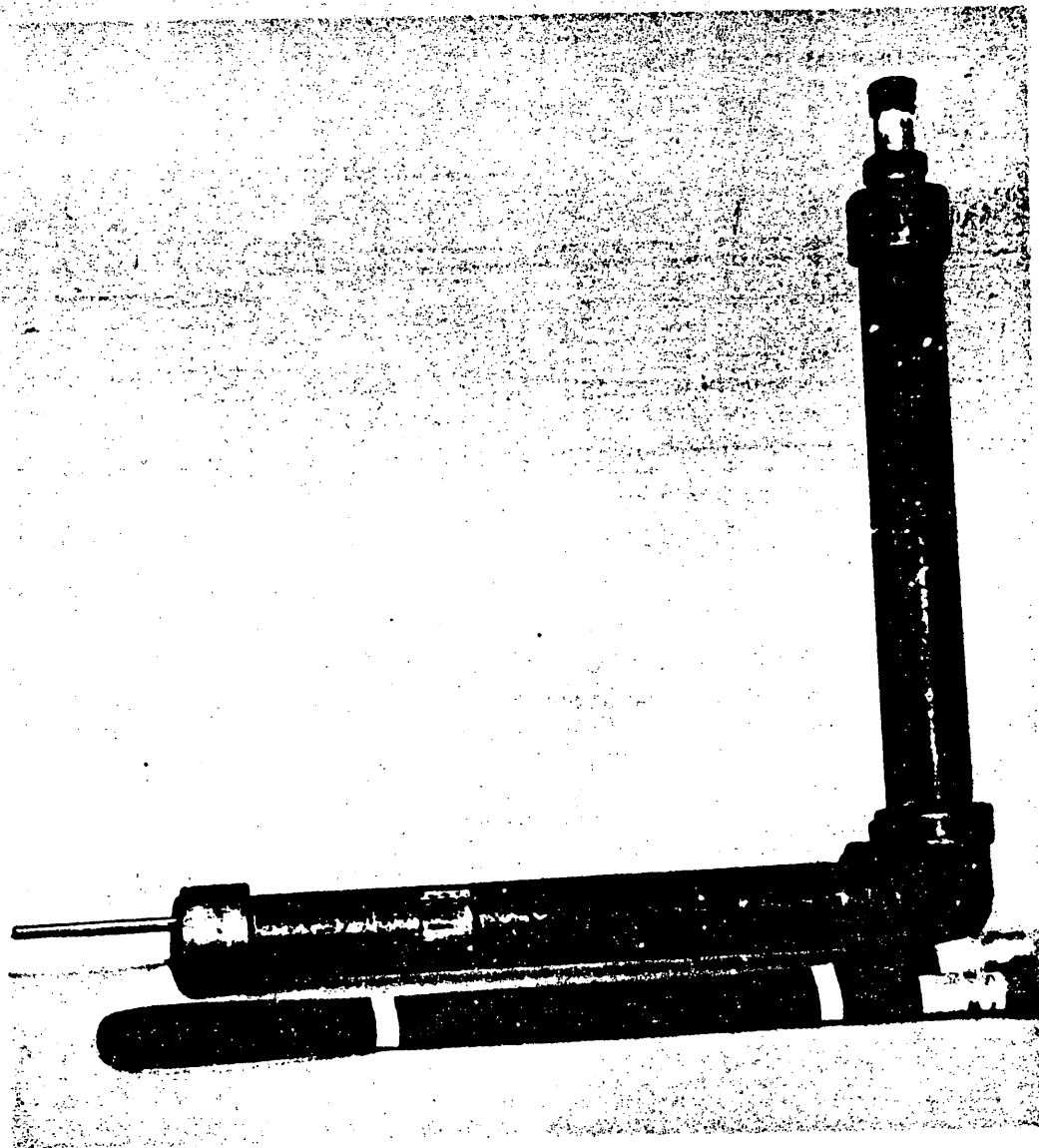

Fig. 7—Photograph of the Experimental Nozzle Apparatus

~~CONFIDENTIAL~~

UNCLASSIFIED

~~CONFIDENTIAL~~

UNCLASSIFIED

This work has clearly demonstrated that ranges of 30 to 40 feet and dispersions of approximately 12 inches in diameter can be achieved at moderate pressures with water, provided that the nozzle is designed and fabricated using the techniques described.

CONCLUSIONS

This feasibility project has been satisfied in the sense that a disabling liquid of nearly ideal character has been found, techniques have been established for satisfactory housing and valving of the liquid in a gun, and the detailed design criteria for a nozzle have been established. It remains for these various elements to be combined in a prototype model which should very closely resemble a production model in appearance and operating characteristics.

This project was directed at demonstrating the feasibility of projecting a stream to a maximum range and with a relatively small dispersion. It is conceivable that applications may exist which would require a greater dispersion at reduced range. That would be a less severe requirement and therefore more easily achieved. In fact, it should be entirely feasible to construct the weapon so that the trade-off between range and dispersion could be selected by the operator.

~~CONFIDENTIAL~~

UNCLASSIFIED

UNCLASSIFIED

~~CONFIDENTIAL~~

APPENDIX A

DESCRIPTION OF LABORATORY USE TESTING

MATERIALS

Five test solutions were used and identified as follows:

1. 15% Capsicum Oleoresin, 85% Mineral oil.
2. 7.5% Capsicum Oleoresin, 92.5% Mineral oil.
3. 100% Light Mineral Oil (for control).
4. 50 Volume Percent Ammonia Solution, 50 Volume Percent Water, plus one (1) milliliter of Water Softener.
5. Capsicum Tincture concentrated to approximately 15% Capsicum, 85% Alcohol-Water Mixture, plus one (1) milliliter of Water Softener.

LABORATORY TESTING

Method

Ocular doses of 0.05 and 1.10 ml and intratracheal doses of 1.10 ml and 0.50 ml of each of the five test solutions, were administered to mongrel dogs. One animal each received a dose of either 0.05 ml in one eye and 0.10 ml intratracheally or 0.10 ml in one eye and 0.50 ml intratracheally of each test solution. Undiluted solutions were used throughout.

Ocular administrations were performed by dropping the solutions into the sack formed by the lower eyelid. The eyes were not washed at any time after dosing.

Intratracheal administrations were performed by puncturing the trachea below the larynx with a hypodermic needle and injecting the solutions directly into the respiratory tree.

All animals were observed for at least ten days post dosing for any gross signs of effect. Gross and microscopic pathological examinations were then performed.

Results

Of the five solutions tested, none produced eye effects at either 0.05 ml or 0.1 ml doses which persisted as long as forty-eight hours. Gross pathological examinations of the eyes were negative in all cases.

~~CONFIDENTIAL~~

UNCLASSIFIED

~~CONFIDENTIAL~~

UNCLASSIFIED

Intratracheal injections of Solutions 1, 2, and 4 produced gross effects at both dose levels which persisted for less than twenty-four hours; Solution 5 produced effects at only the high level which persisted for less than twenty-four hours. Solution 3 produced no effects. Gross pathological examinations indicated lung damage, possibly compound induced, in animals receiving doses of 0.10 ml and 0.50 ml of Solution 1. Compound induced pneumonia was reported in the animal receiving 0.50 ml of Solution 2. This was the second animal tested at this dose level. The animal receiving 0.10 ml was not affected. Solution 3 produced no effects. Pneumonia, possibly compound induced was reported in the animal receiving 0.50 of Solution 4, but not in the animal receiving 0.10 ml. Pneumonia was reported in the animal receiving 0.50 ml of Solution 5. This animal was the second test at this dose level. Kidney damage, probably compound induced, was reported in the animal receiving 0.10 ml of Solution 5. This animal died 28 days post-exposure and was the second tested at this dose level.

Repeat testing was performed with Solution 2 at the 0.10-0.50 ml level due to loss of the animal's identification tag in the kennel. Solution 5 was repeated at both the 0.05 - 0.10 ml level and the 0.10 - 0.50 ml level; since both animals had been grossly diagnosed as having distemper and the fact that the animal receiving the 0.05-0.10 ml dosage died nine days post dosing and pathological examination of the dog receiving the 0.10-0.50 ml dosage indicated pneumonia, probably compound induced.

These test results are summarized in Table A-1.

USE TESTING

Method

Subsequent to the laboratory tests described above, each solution was tested against aggressive dogs.

Prior to administration of the test solutions each animal was provoked to the point where it would attack. At this point, a dose of 10 milliliters of the test solution was directed at the animal's head (in the form of a stream) from a hypodermic syringe or a water pistol. Response times and recovery times were then recorded. Control tests were performed with Solution 3 (100% light mineral oil) and with a preparation dispersed as an aerosol from a pressure can.

~~CONFIDENTIAL~~

UNCLASSIFIED

UNCLASSIFIED

TABLE A-1
RESULTS OF OCULAR AND INTRATRACHEAL TOXICITY TESTING IN DOGS (U)

Soln. Ident. No.	No. Dogs Dosed	Route	Dose (per animal)	Response (hrs post-dosing)			Mortality	Gross Pathology and Remarks
				> 1	24	48		
1	1	Ocular	0.05	a, b	c, d	N	Multiple sub-pleural lung hemorrhage, possibly compound induced, eyes unremarkable.	
		It	0.10	1, 2, 3	N	N		
1	1	Ocular	0.10	a, b	b, c, d	N	Red foci pleural right diaphragmatic lung, possibly capd induced. Eyes unremarkable.	
		It	0.50	1, 2, 3	N	N		
2	1	Ocular	0.05	a	b, c	N	Small white sub-pleural nodule. Not capd induced. Eyes unremarkable.	
		It	0.10	1, 2	N	N		
1	1	Ocular	0.10	a, b	N	N	NOTE: Animal identification tag lost. Dose repeated (see below).	
		It	0.50	1, 2	N	N		
1	1	Ocular	0.10	a, b	b	N	Resolving pneumonia, capd induced. Eyes unremarkable.	
		It	0.50	1, 2	N	N		
3	1	Ocular	0.05	N	N	N	Trachea, lungs and eyes unremarkable.	
		It	0.10	N	N	N		
1	1	Ocular	0.10	N	N	N	"	
		It	0.50	N	N	N		
4	1	Ocular	0.05	a	c, e	N	Trachea, lungs and eyes unremarkable.	
		It	0.10	1, 2	N	N		
1	1	Ocular	0.10	a	b, c, d	N	Interstitial pneumonia, both lobes of lung, probably capd induced. Eyes unremarkable.	
		It	0.50	1, 2, 3	N	N		
5	1	Ocular	0.05	a, b, c	N	N	NOTE: Diagnosis immediately prior to death indicated distemper. Doses repeated (see below)	
		It	0.10	N	N	N		
1	1	Ocular***	0.05	a	c	N	Fibrous plaque right tricuspid. Bilateral mild chronic interstitial seborrhis (both conditions probably capd induced). Eyes unremarkable.	
		It	0.10	N	N	N		
1	1	Ocular	0.10	a, b, c	N	N	Diagnosis pre pathology exam. Indicated distemper. Gross path, indicated pneumonia probably capd induced. Eyes unremarkable	
		It	0.50	1, 2, 3, 4	N	N		
1	1	Ocular***	0.10	a	c, e	N	Resolving pneumonia, capd induced. Eyes unremarkable.	
		It	0.50	4	N	N		

* Same animal used for both ocular and intratracheal dosings at respective dose levels.

** Responses: a. Closed eyelids d. Blepharitis 1. Coughing 4. Retching
 b. Swollen eyelids e. Lacrimation 2. Licking see Repeated tests.
 c. Conjunctivitis N. Normal 3. Salivation

CONFIDENTIAL

UNCLASSIFIED

~~CONFIDENTIAL~~

UNCLASSIFIED

Results

None of the five solutions produced effects which could be considered to be incapacitating or debilitating to the degree that the dogs would not attack. Of the four solutions, numbers 1 and 2 produced the most severe irritation but their duration of action was too short to significantly reduce aggressiveness.

Animals dosed with the aerosol preparation were markedly effected. One of two dogs tested against this device could be approached for 2 minutes after dosing, after which time he again became aggressive but would shy when shown the spray can. The second dog, an extremely vicious animal, although severely irritated by the spray, could not be approached immediately after dosing.

Twenty-four hours after dosing all test animals appeared grossly normal. A summary of these observations is shown in Table A-2.

The results of pathological examinations performed on the animals used for these tests will be reported in the final project report with the microscopic pathological examinations of tissues from those animals receiving ocular and intratracheal doses.

Summary of Toxicity Determinations

None of the compounds tested produced ocular effects at doses of either 0.05 ml or 0.10 ml which persisted longer than 48 hours. No permanent eye damage was detected by gross pathological examination.

Gross signs of lung damage appeared after intratracheal administration of the Capsicum-mineral oil, Capsicum-tincture, and ammonia-water solutions. The compounds might have been a predisposing factor. Mortalities were produced in both animals receiving the 0.05-0.10 ml doses of Capsicum tincture and kidney damage was reported in the repeat animal. Light mineral oil produced no effect.

Applications of compounds in the forms described under use testing produced only transitory effects which disappeared completely in less than twenty-four hours.

~~CONFIDENTIAL~~

UNCLASSIFIED

UNCLASSIFIED

CONFIDENTIAL

TABLE A-2
RESULTS OF USE EVALUATIONS IN AGGRESSIVE DOGS (U)

Dog No.	Solution No.	Vol. Soln. Sprayed (cc)	Time to Onset	Responses	Time to Recovery	Remarks
1	1	10	Immediate eye irritation and salivation		3 min	Dog still aggressive immediately after dosing. Could not be approached.
-	-	..*	Immediate severe eye and nasal irritation		4 min	Not aggressive for 2 min after dosing but continued to shy when shown spray can.
3		10	No effect		-	-
2	2	10	Immediate eye irritation and retching		3 min	Dog still aggressive immediately after dosing.
3	4	10	No effect		-	-
4	5	10	Slight irritation		-	-
-	-	..*	Immediate severe eye and nasal irritation		4 min	Very vicious animal, requiring extreme care in handling. Could not be approached immediately after dosing.

* Aerosol Spray

UNCLASSIFIED

CONFIDENTIAL

~~CONFIDENTIAL~~

UNCLASSIFIED

APPENDIX B

FLUID DYNAMICS OF PROJECTING A JET OF LIQUID

INTRODUCTION

The Bowles Engineering Corporation studied the fluid dynamics of projecting a pulse of liquid from location A to location B. As general objectives, it was desired that:

The distance A-B should be 30-40 feet.

The jet dispersion normal to trajectory at location B should be of the order of 12 inches.

The pulse should contain approximately 1 cc of liquid.

It should be feasible to generate a train of pulses.

The contribution of Bowles Engineering Corporation was to furnish guidance which would help establish the design parameters and feasibility of these objectives.

INTERNAL FLUID TRANSFER

This portion of the problem covers transfer of fluid from a reservoir to a nozzle.

Gas - Liquid Interfaces

One method of driving liquid is with a pressurized gas. If this is accomplished under conditions wherein the interface velocity is low, then the gravitation field is adequate to keep the gas from causing severe mixing problems unless the gas is soluble in the liquid. (For example, a CO_2 - H_2O interface under pressure will result in carbonated water which will release gas bubbles as the mixture flows through the nozzle. The resulting jet will change to spray at a reduced range compared to a continuous liquid jet due to transverse velocity perturbations introduced by the release of CO_2 bubbles.) If the gas - liquid interface at the trailing surface of the liquid column is under high acceleration, then a dramatic and severe disturbance of the liquid volume integrity occurs. The gas volume penetrates the interface center forming a hollow liquid cylinder. Subsequently, the penetrating gas finger entrains liquid from the surrounding liquid cylinder, introduces instabilities within the liquid cylinder; the instabilities grow.

~~CONFIDENTIAL~~

UNCLASSIFIED

UNCLASSIFIED

CONFIDENTIAL

and a gas - liquid mix is created which will eject from the nozzle as a fine mist.

Presence of a gas interface at the leading surface of the liquid column also results in severe distortion. Wall drag causes the periphery of the leading surface to lag the center portion and destroys sharpness of the leading portion of the jet. In addition, if the passage is locally wetted by surface droplets, then those droplets will generate destructive instabilities in the leading portion of liquid flow and so destroy jet integrity.

Thus, it is important that the internal passages of the weapon be filled entirely with liquid and that the liquid be driven either by a liquid-solid interface or by a low velocity liquid-gas interface wherein the gas has a low tendency to dissolve in or combine with the liquid.

Straightening Vanes

Flow around obstructions or bends in the flow channel will introduce turbulence, vortices, and non-uniform velocity profiles. Such inhomogeneity is detrimental to the jet performance.

Straightening vanes are useful in reducing the amplitude and scale of larger size high amplitude vortices, eddies, turbulences, and misaligned flow conditions.

Straightening vanes of slim design should be used. An NACA 633-018 profile is a good one to use. However, sheet stock with rounded leading edge and symmetrically sharpened trailing edge should be adequate. The vane chord should be no less than twice the vane separation. Two sets of vanes with a gap separating the two sets and/or any screens is recommended. The gap should be no less than twice the vane chord length.

Screens

The function of the screening is to provide a low turbulence level and parallel, uniform flow of the fluid to the nozzle entrance.

The screen solidity is the projected wire area (shadow) per unit of total projected area when viewed in a direction normal to the plane of the screen. If the solidity is high, the screen can introduce turbulence rather than provide the desired attenuation. We were able to obtain a stainless steel screen having solidity of the order of 0.3. This was felt to be acceptable, although 0.2 was

UNCLASSIFIED

CONFIDENTIAL

~~CONFIDENTIAL~~

UNCLASSIFIED

indicated by calculations to be more desirable. If the screen is viewed other than along this "normal" line, the apparent solidity is increased. Similarly, the screen offers a high resistance per unit area to flow inclined to the "normal" than is offered to flow in the normal direction.

In addition, the pressure drop across the screen is greater for high velocity portions of the flow than for low velocity portions. The screens tend to:

- Even out the flow velocity distribution.
- Make the flow direction normal to the plane of the screen.
- Reduce turbulence level.
- Reduce turbulence scale, i.e., size.

The best screening combination tested consisted of five layers having 50 x 50 mesh of .003" diameter stainless steel wire. Use of lower solidity screen and more layers of screen would provide an improvement.

Additional screen sections had negligible effect in our test setup due to excessive screen solidity.

Fewer screen sections provided a noticeable increase in jet surface turbulence.

Four layers of stainless steel wire screen should be used. The screen solidity should be approximately .2. See Jet Stability section of this appendix for parameters of wire diameter.

Surface Finish

The nozzle and approach channel surface finish establishes the jet surface turbulence level. We found a distinct improvement when a 16 microinch surface was polished to an 8 microinch finish. Our final test nozzles were polished to provide a surface of between 4 and 8 microinch finish.

We believe that a 4 microinch surface finish would be a worthwhile objective for a production model.

~~CONFIDENTIAL~~

UNCLASSIFIED

UNCLASSIFIED

~~CONFIDENTIAL~~

THE NOZZLE

The objective of this nozzle design is a uniform parallel jet having a smooth surface and zero vorticity. Such a jet will travel a maximum distance.

Turbulence and vortices have associated velocity components normal to the direction of jet motion. Once outside of the nozzle, there is no solid boundary to limit the associated liquid displacements and one of two actions result. If these disturbances are sufficiently large, they will cause the jet to diverge and disperse as a spray. If these disturbances are small, they will cause the jet surface to become wavy. It is a characteristic of subsonic flow that pressure distributions will be developed by the relative motion of the surrounding air which will cause these wavy perturbations to grow and be amplified. As the perturbations grow, the local liquid jet is no longer following and shielded by the preceding portions of the jet. Consequently, there is an increased drag and the jet is further distorted. This distortion causes a necking of the liquid to an extent that surface tension causes the jet to segment. These segments then form into drops. As the drops scatter, they encounter "slower" air and disperse farther to the side and break into smaller droplets.

The approach to nozzle design is to:

Provide straightening vanes to remove large scale vortices and eddies in the approaching flow.

Provide screens to improve uniformity of the velocity profile of the approaching flow and remove small scale turbulence.

Provide a nozzle profile which will accelerate the fluid from a slow uniform parallel flow to a fast uniform parallel flow.

Provide a sharp exit and a smooth surface finish to minimize jet surface displacement perturbations.

The straightening vanes, screens, and surface finish have been discussed. The nozzle profile design, nozzle size and nozzle tests will follow.

~~CONFIDENTIAL~~

UNCLASSIFIED

UNCLASSIFIED

Nozzle Profile Design

Several methods are available for the design of contracting sections which will give a uniform velocity distribution at a nozzle exit. These analyses are based on potential theory, and hence no boundary layer effects are taken into account. An expression for the velocity potential is found from a solution of Laplace's Equation. From this potential, the velocity components can be obtained by differentiation, and these, when integrated, yield the stream function.

One nozzle was constructed using the method proposed by Thwaites¹. A monotonic axial velocity distribution in the form of a Fourier Series was assumed. Further restrictions were that the contraction section be bounded by equipotential surfaces, and that the velocity component normal to the nozzle axis be positive everywhere within the nozzle, and zero at the end sections. This would insure a uniform velocity distribution at the exit.

Truncation of the series gives a velocity distribution that is not truly uniform, which is apparent from the fact that the walls at the exit section are not parallel, Figure B-1. The nozzle shown is the result of a 3-term series and the computations with a more complete series becomes unruly. In order to improve the exit section flow pattern, the slope one nozzle width from the design exit section was chosen to be one half the slope at the design exit section. This was then faired into a parallel wall section three nozzle widths from the design exit section. Thus, the nozzle was lengthened three design nozzle widths beyond the design exit section in order to avoid complicated calculations.

The nozzle thus constructed was to be compared with a theory presented by Shima², since experimental data which substantiates the validity of his theory is contained in the paper. Shima's development parallels Thwaites', but the former uses a Taylor Series. The velocity distribution of Thwaites was substituted in

1. Thwaites, B. "On the Design of Contractions for Wind Tunnels," A R. C R&M #2278, March, 1946.
2. Shima, A. "Method to get Profile of Nozzle with Given Velocity Distribution along Nozzle Axis/Report 2" Rep. Inst. High. Sp. Mech. Japan, Vol. 14 (1962/1963), Pages 135/152.

CONFIDENTIAL

UNCLASSIFIED

UNCLASSIFIED

~~CONFIDENTIAL~~

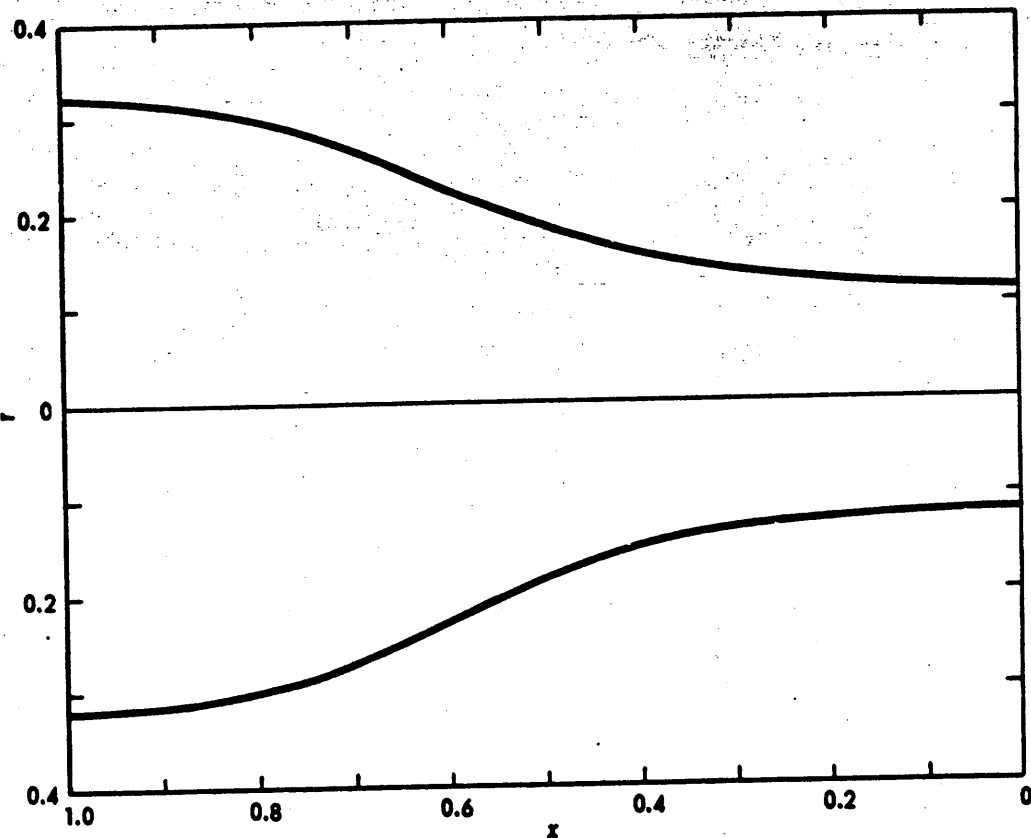

Fig. B-1-3-D, Potential, No B. L. Correction

x	r
0	0.1115
0.120	0.1165
0.249	0.1274
0.343	0.1430
0.412	0.1591
0.514	0.1914
0.594	0.2230
0.667	0.2550
0.750	0.2875
0.814	0.3030
0.875	0.3120
1.000	0.3190

~~CONFIDENTIAL~~

UNCLASSIFIED

~~CONFIDENTIAL~~

UNCLASSIFIED

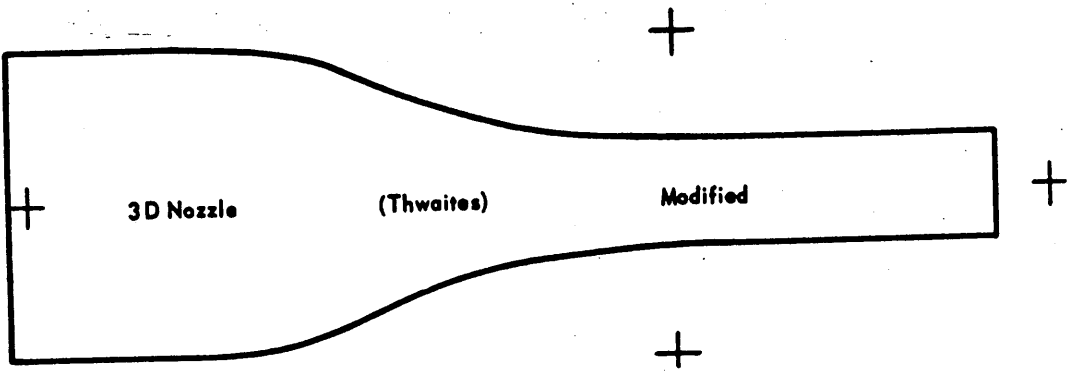

Fig. B-2—Nozzle Profile

~~CONFIDENTIAL~~

UNCLASSIFIED

UNCLASSIFIED

~~CONFIDENTIAL~~

the method of Shima and the mathematics carried out to the point where they became impossible to calculate with a desk calculator. Without the aid of a computer, the comparison could not be made further.

The above axially symmetric nozzle design is shown by Figure B-2 and is the design proposed and tested.

Sample Calculation

In solving the differential equation for velocity potential and appropriately differentiating, Thwaites finds the velocity component to be

$$u = a + \sum_{p=1}^N a_p (\cos px) I_0(pr) \quad (1)$$

This gives

$$\left(\frac{\partial u}{\partial x}\right)_{r=R} = - \sum_{p=1}^N P a_p (\sin px) I_0(pR) \quad (2)$$

To satisfy the restriction of a monotonically velocity on the boundary, a_p must be chosen such that

$$\left(\frac{\partial u}{\partial x}\right)_{r=R} = -B(1 + \cos x)^{n-1} \sin x \quad B > 0 \quad (3)$$

Expanding and equating equation 2 & 3 gives, for $N = 3$,

$$I_0(1) a_1 + 4a_2 I_0(2) \cos x + 3a_3 I_0(3) (4 \cos^2 x - 1) = B(1 + 2 \cos x + \cos^2 x)$$

Hence, by equating coefficient,

$$\frac{a_1 I_0(1) - 3a_3 I_0(3)}{1} = \frac{4a_2 I_0(2)}{2} = \frac{12a_3 I_0(3)}{1} = B$$

on taking $a_1 = 1$,

$$a_2 = \frac{2 I_0(1)}{5 I_0(2)} \quad a_3 = \frac{1 I_0(1)}{15 I_0(3)}$$

Then from the solution for the stream function which was derived,

$$\psi = \frac{1}{2} a_0 r^3 + r \sum_{p=1}^N \frac{a_p}{P} (\cos px) I_1(pr) \quad (4)$$

~~CONFIDENTIAL~~

UNCLASSIFIED

~~CONFIDENTIAL~~

UNCLASSIFIED

And equating the value of the stream function at the two points at either end of the bounding streamline (i.e., the points $x=0, r=0.35; x=\pi, r=1$)

$$\frac{1}{2} a_0 (0.35)^2 + 0.35 \{ a_1 I_1(0.35) + \frac{1}{2} a_2 I_1(0.7) + a_3 I_1(1.05) \} \\ = \frac{1}{2} a_0 \sim \{ a_1 I_1(1) - \frac{1}{2} a_2 I_1(2) + \frac{1}{3} a_3 I_1(3) \} \quad (5)$$

can be found, and then from (4), ψ on the boundary can be found (call this $\psi = \psi^*$). Now the ordinates of this bounding streamline can be found from

$$\psi^* = \frac{1}{2} a_0 r^2 + \sum_{p=1}^3 \frac{a_p}{p} (\cos px) I_1(pp) \quad (6)$$

The constants computed were:

$$a_1 = 1$$

$$a_2 = 0.22216$$

$$a_3 = 0.01729$$

$$a_0 = 1.11481$$

$$\psi^* = 0.14614$$

Using the constants (equation 7) in equation 6, r vs x can be found for the bounding streamline (Figure B-1).

Nozzle Size

One of the requirements for this nozzle was a small jet diameter. For larger jets, a high surface tension tends to reduce small surface perturbations. However, in small jet sizes, the surface tension also tends to break the jet into particles which subsequently become spherical. This is shown by the jet photographs of this report.

The nozzle tested had an exit internal diameter of .137 inches. We recommend that the final diameter selected be as large as is feasible but in no event less than .025 inch diameter. Smaller sizes will both reduce jet range and require more stringent fabrication tolerances.

~~CONFIDENTIAL~~

UNCLASSIFIED

UNCLASSIFIED

~~CONFIDENTIAL~~

Nozzle Tests

Test Apparatus. Figure B-3 shows the general system used for tests conducted. Water from the city mains was used as a supply. Maximum consistent pressure attainable at the test apparatus was 25 psig. This provided steady state long duration tests to examine details of the jet structure.

The configuration was also used for tests at pressures above 100 psig. In these tests the pistol assembly was first charged with water. Subsequently, high pressure air was applied, instead of city water pressure, and provided short duration tests at pressures up to 700 psig. The pistol assembly is suitable for tests at higher pressures as it is constructed of 3000 psi pipe.

Figure B-4 illustrates an alternate arrangement used in a subsequent test. The tank was first filled with water. Next, the quick opening valve was opened and the compressed air entered the tank to provide steady static pressure over the range of 1 to 78 psig.

Figure B-5 is a cross sectional view of the pistol assembly of Figures B-3 and B-2.

A copper flow pipe separated the liquid supplied to the "old" or reference nozzle from the liquid supplied to the new nozzle. Thus, the pressure loss of straightening vanes and screens associated with the new nozzle did not effect flow to the old nozzle. Figure B-5 shows only one set of straightening vanes preceded and followed by a spacer and a heavy duty screen. Five "fine" screens are shown followed by a large contraction followed by a small contraction. Each of these contractions provided a potential flow area reduction of 5:1.

The old nozzle was a 6" length of .125" ID brass tube reamed to .127" ID with a high internal polish. This was used to provide a reference jet.

Due to assembly problems, the old nozzle exit was six inches downstream of the new nozzle exit. Consequently, two scales are given in each jet comparison photograph. Each scale represents distance from the nozzle exit for the associated jet.

Figure B-6 presents the flow straightening vane assembly used for most of the tests. Three sets of straightening vanes are

~~CONFIDENTIAL~~

UNCLASSIFIED

~~UNCLASSIFIED~~

~~CONFIDENTIAL~~

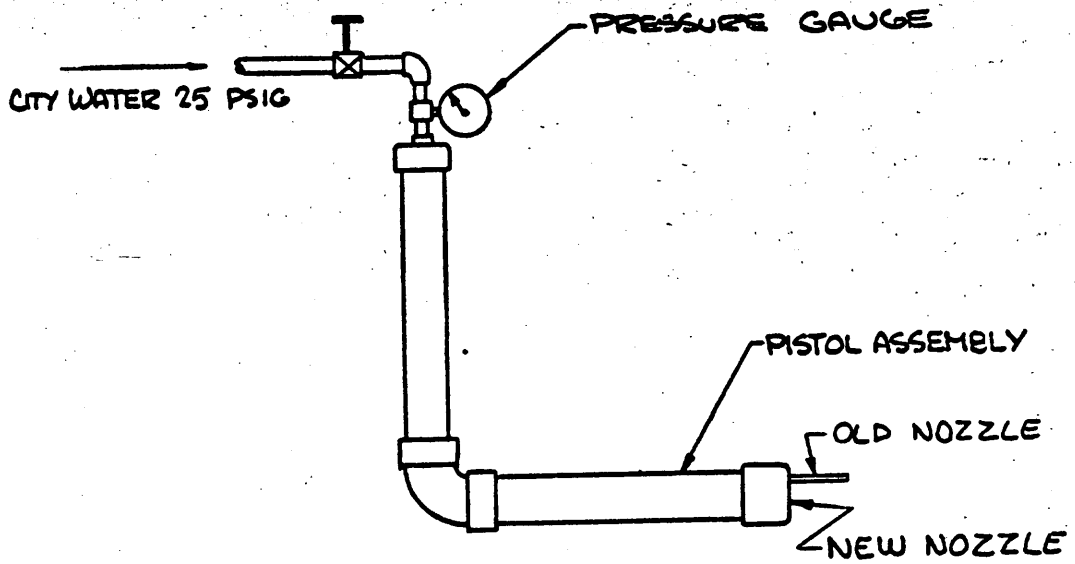

Fig. B-3

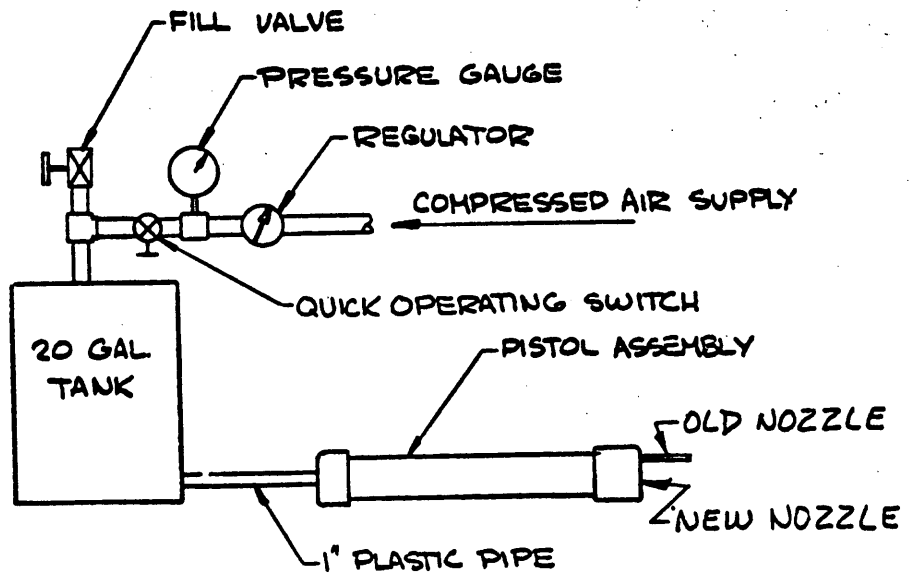

Fig. B-4

~~CONFIDENTIAL~~

UNCLASSIFIED

~~CONFIDENTIAL~~

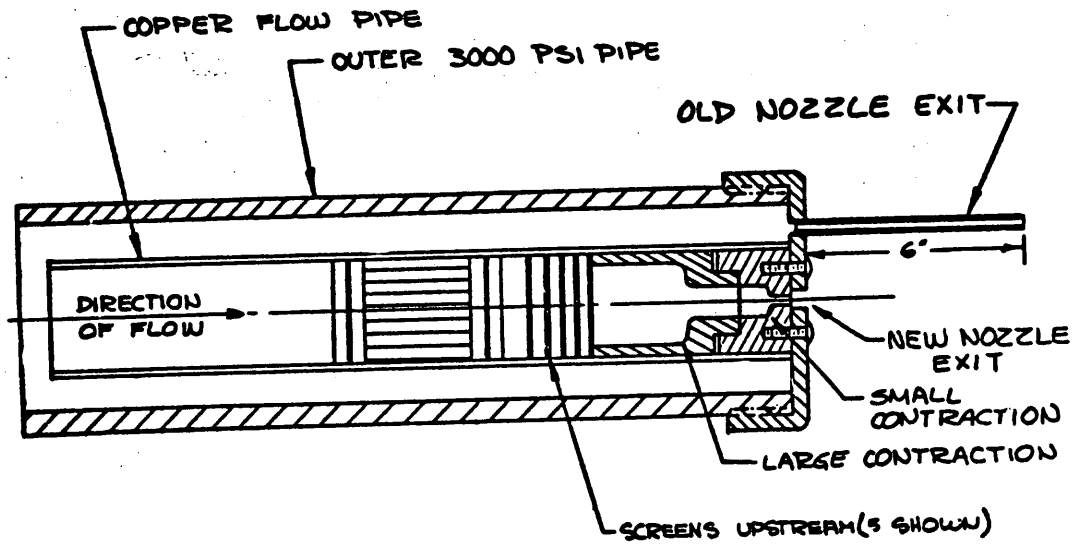

Fig. B-5—Pistol Assembly With One Set of Straightening Tubes and 2 Spacing Screens

~~CONFIDENTIAL~~

UNCLASSIFIED

CONFIDENTIAL

UNCLASSIFIED

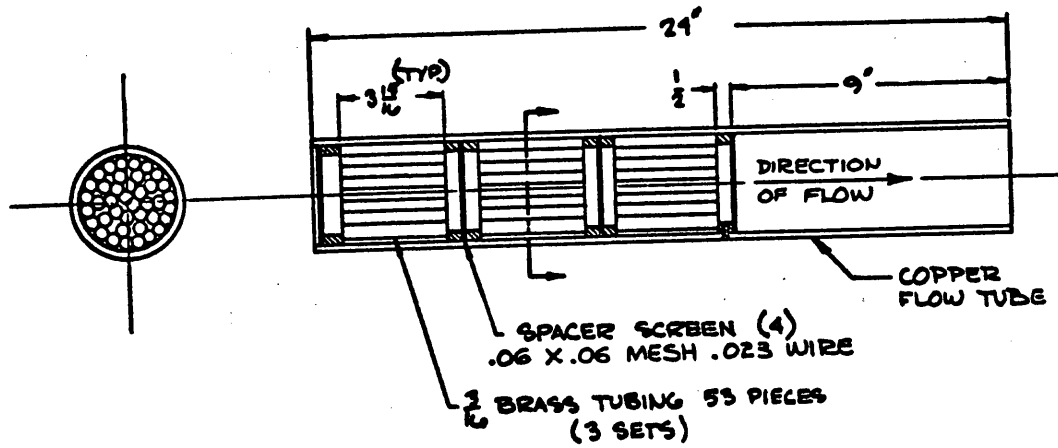

Fig. B-6—Flow Straightening Vane Assembly

CONFIDENTIAL

UNCLASSIFIED

~~CONFIDENTIAL~~

provided rather than a single set as illustrated in Figure B-5. The large contraction and small contraction fitted snugly within the copper flow tube downstream end at assembly.

Use of circular rather than pie-shaped sections left some residual vorticity in the flow; however, tests did not indicate it was the source of jet nutation which persisted to the final tests.

To evaluate effectiveness of the straightening vanes, tests were conducted wherein the straightening vanes were removed and stagnant water was driven toward the nozzle by a piston. There was no discernible difference between the photographs of jets supplied by this flow and that of flow controlled by straightening vanes.

Test Series A. Figure B-7 compares the jet of the "old" Nozzle A and the new Nozzle B. Note the new nozzle jet is pictured at a location six inches farther from its nozzle exit than for the old nozzle jet, hence, the two distance scales. Also, the photographs are such that the jets are 1:1 scale. The tape measure is at a greater distance from the camera and so is at a reduced scale and exhibits parallax.

It is apparent that the new jet is significantly better than the "old" or reference jet. The old jet has started to segment at a range of one foot four inches, while the new jet is still continuous at the last observed point, 4" - 3". The new jet is, however, nutating about its centerline as if the nozzle was being swept around a circle concentric with the nozzle centerline providing a conical surface having an apex semi angle of $\frac{1}{400}$ radian.

Note how the segments of the old jet try to form spherical shapes at 2' - 6" but start to break up into smaller globes at ranges over 3' due to increased air resistance encountered as their displacement from the jet centerline increases.

~~CONFIDENTIAL~~

UNCLASSIFIED

~~CONFIDENTIAL~~

Note that in all of the preceding figures, the quality of the new jet is definitely superior to that of the reference jet. Ground impact range was 50% greater for the new jet than for the old jet.

Test Series E. Figures B-11 and B-12 compare the reference and new nozzle jets at pressures from 17 psig to 50 psig.

At pressures above 25 psig, the nutation amplitude increases with supply pressure. The nutation wave length also increased with a non-longitudinal dimension. This further indicates problems associated with screen solidity but is not conclusive.

Photographs using a mirror to get simultaneous top and side views proved the nutating nature of the jet profile.

Other Tests. At high pressure the jet divergence angle increases. Mean droplet size decreases as pressure increases. Also, mean droplet size decreases as the droplets come out from behind the shield provided by the liquid, which remains on the jet centerline.

The new nozzle performance was significantly better than the old nozzle performance at all pressures tested. The improvement became progressively more noticeable with increasing pressure above 20 psig up to about 400 psig. At higher pressures things became very foggy.

Conclusions

The new jet represents a major improvement over the old jet. Surface finish of four microinch quality is needed.

The jet is a good one but it nutates at a small angle at about 1500 cps.

If this nutation can be eliminated, another major improvement can be provided.

There is evidence to support the hypothesis that the fine screens are the source of the nutation perturbation and that this effect can be reduced by change of the fine screen design. This design change would include a reduction of screen solidity from the test value of .3 to the original design point of .2. Such screens are special order items but are available.

Improvements in useful range of about 50% over those provided by the reference nozzle were achieved during this program.

~~CONFIDENTIAL~~

CONFIDENTIAL

UNCLASSIFIED

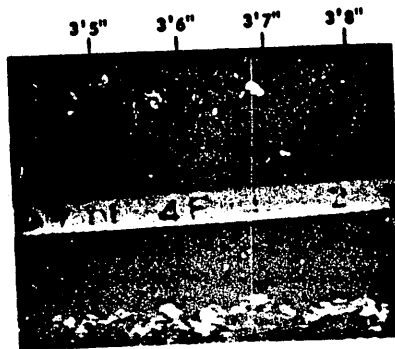
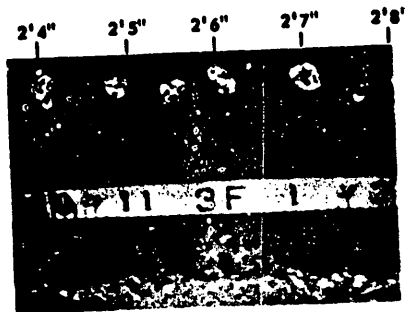
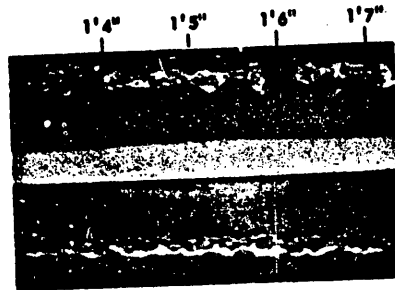
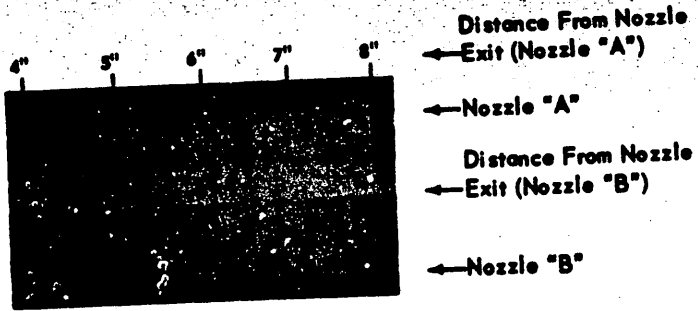
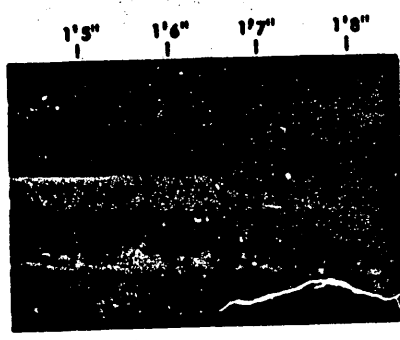
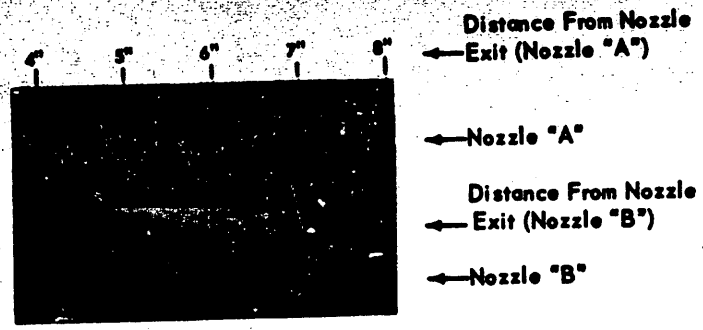

Fig. B-7-Test Series A

CONFIDENTIAL

UNCLASSIFIED

~~CONFIDENTIAL~~



FLOW DIRECTION →

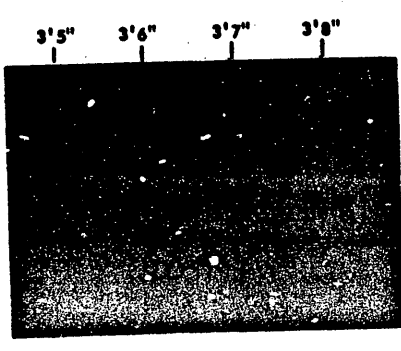

Fig. B-8-Test Series B

CONFIDENTIAL

UNCLASSIFIED

~~CONFIDENTIAL~~

UNCLASSIFIED



Distance From Nozzle
← Exit (Nozzle "A")

← Nozzle "A"

Distance From Nozzle
← Exit (Nozzle "B")

← Nozzle "B"

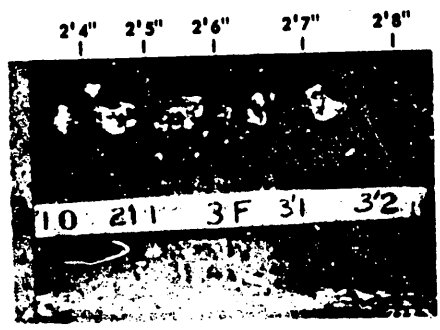

FLOW DIRECTION
→

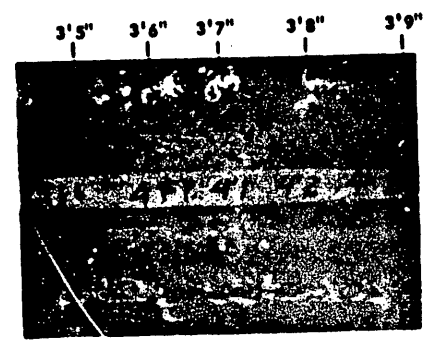

Fig. B-9-Test Series C

~~CONFIDENTIAL~~

UNCLASSIFIED

UNCLASSIFIED

~~CONFIDENTIAL~~

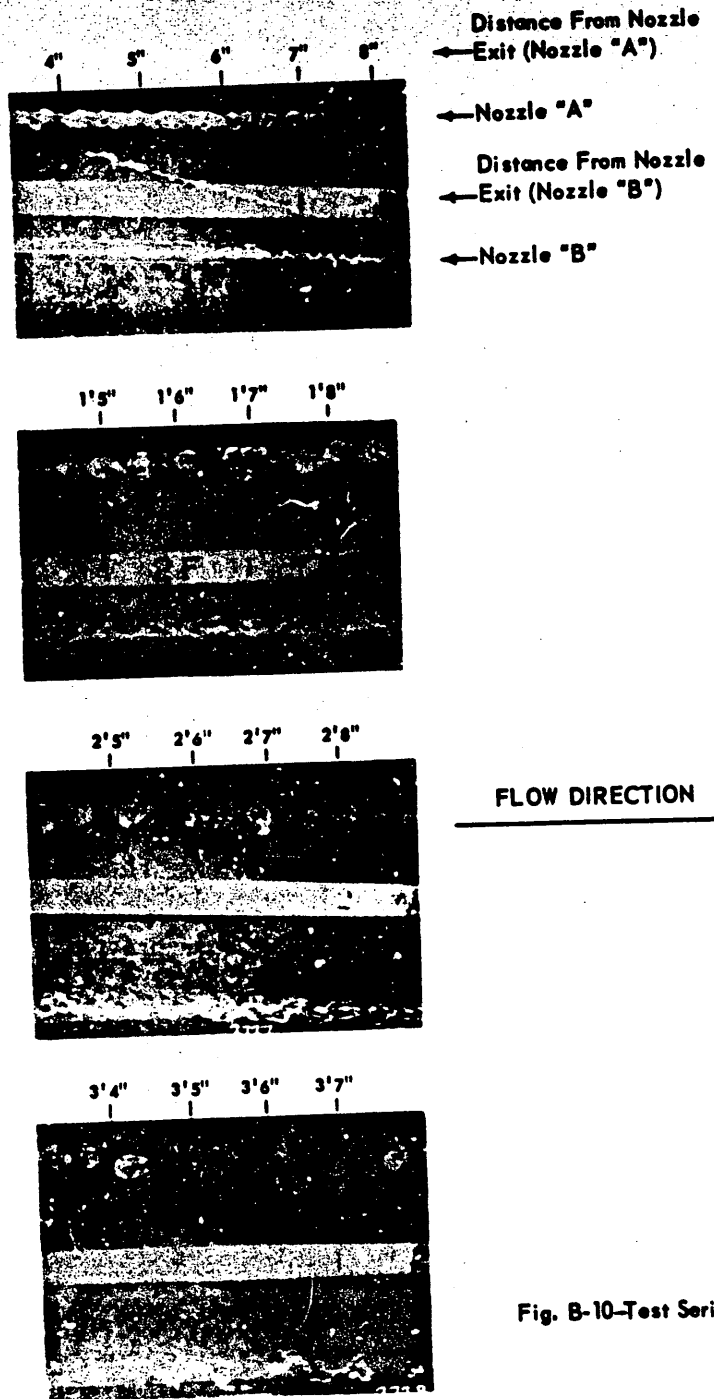

Fig. B-10-Test Series D

~~CONFIDENTIAL~~

UNCLASSIFIED

DATA

Nozzle "A" _____ Double Contraction Nozzle
(New) .137 Exit I. D.
Nozzle "B" _____ .125-.127 I. D. Tube
(Reference)
Screens Upstream _____ 30 x 30 Mesh, .0065 Wire
Spacer Screens _____ 4
Straightening Tubes _____ 3 Sets
Photograph Time _____ 2 Micro Secahd
Test Date _____ 11 Nov. 64

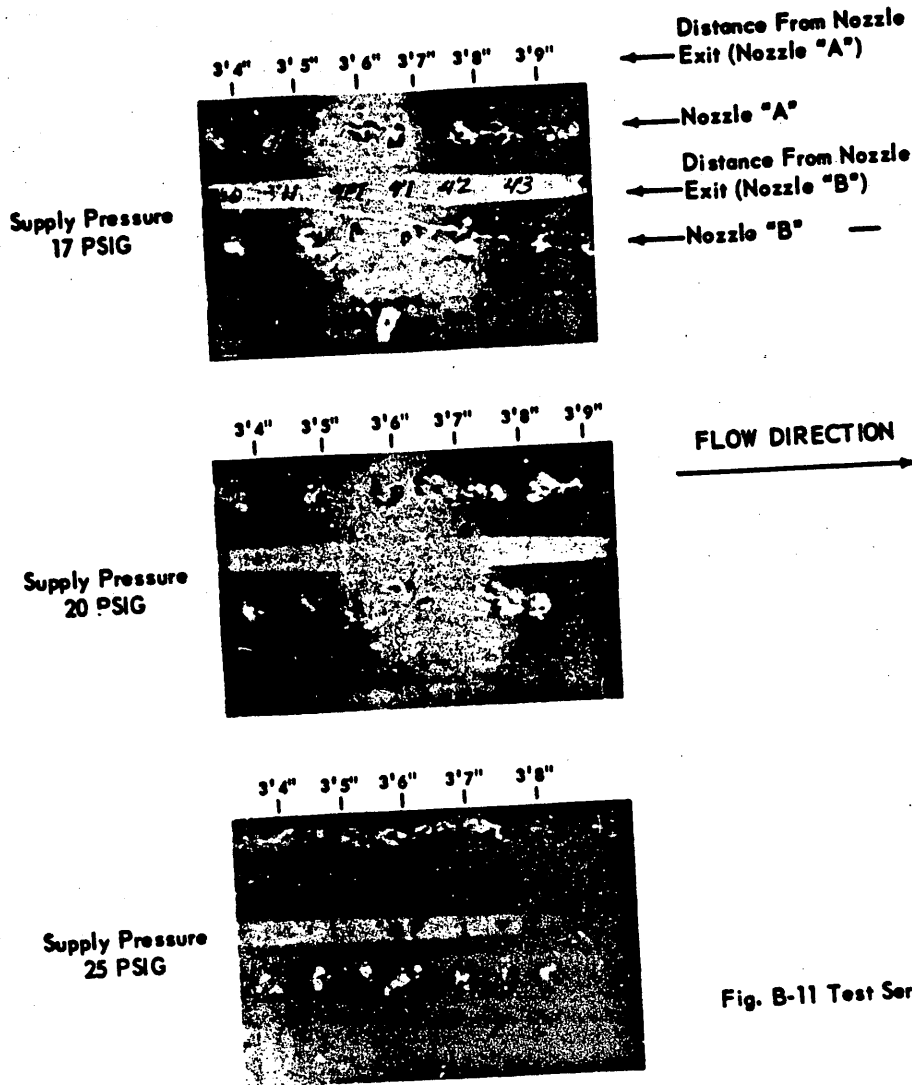

Fig. B-11 Test Series E

CONFIDENTIAL

UNCLASSIFIED

UNCLASSIFIED

~~CONFIDENTIAL~~

Supply Pressure
30 PSIG



← Distance From Nozzle
Exit (Nozzle "A")

← Nozzle "A"

← Distance From Nozzle
Exit (Nozzle "B")

← Nozzle "B"

Supply Pressure
35 PSIG

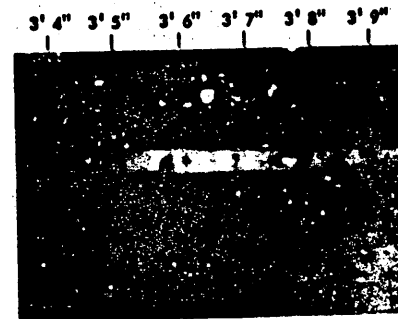

Supply Pressure
40 PSIG

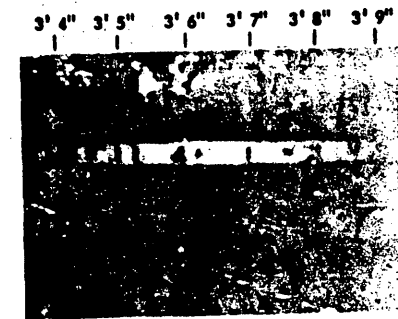

FLOW DIRECTION
→

Supply Pressure
50 PSIG

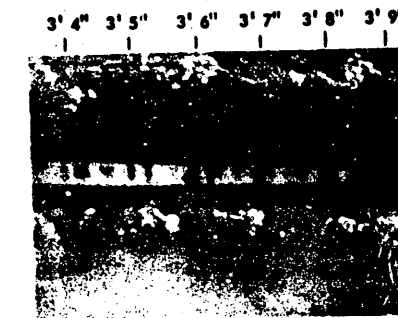

Fig. B-12 Test Series E (continued)

~~CONFIDENTIAL~~

UNCLASSIFIED

UNCLASSIFIED

JET INTERRUPTION

Flow pulsing initially promised to provide a way to conserve fluid and still maintain weapon effectiveness. Two approaches were tried to pulsing or jet duration control. One approach used moving parts and might be termed a mechanical approach. A second method utilized jet interaction.

Although pulsing techniques were not pursued to completion because of the size of initial models and fund limitations, the results are presented for future reference.

Pulse Duration

Let us make a simplified analysis to establish the pulse length.

Assumptions:

Range = R = 40 ft

Allowable drop = S = 1 ft

Then the liquid flight time t in a vacuum is:

$$t = \sqrt{\frac{2S}{g}}$$

$$= \sqrt{\frac{2}{32.2}}$$

$$= .25 \text{ sec.}$$

The corresponding jet velocity v is

$$v = \frac{R}{t}$$

$$= 160 \text{ fps}$$

Assumptions:

Nozzle diameter = $d = .125$ "

Liquid Volume = $V = 1$ cc

The nozzle Area = $A = .0795 \text{ cm}^2$

The length of the liquid slug = $l = 12.57$ cm

The velocity $v = 160 \text{ fps} = 4872 \text{ cm/sec}$

CONFIDENTIAL

UNCLASSIFIED

~~CONFIDENTIAL~~

The pulse duration = t

$$t = 12.57/4872$$

$$= 2.58 \text{ milliseconds}$$

This is rather short for conventional hydraulic devices.

Mechanical Pulse Generators

We examined two means of generating the fluid pulses via mechanical controls.

Spool Valve Mechanical Pulse Generation. Figures B-13 and B-14 show one arrangement using two spool valves as an oscillator. This was assembled to examine the characteristics of mechanical pulse generation.

The assembly was tested using 1/4" polyflow tubing connections (which are sufficiently flexible to present a capacitance effect) and pressures in the range from 40 psig to 80 psig. Oscillation frequency was adjusted by restricting vent (x). As a mechanical trigger mechanism was not included in the test set-up, the left spool valve was opened partially, the air was turned on slowly, and oscillation was initiated by opening vent (x) rapidly. At higher frequencies, vent (y) was opened simultaneously with vent (x).

The frequency was varied between 10 pps and 40 pps by adjustment of vent (x). The frequency could also be varied by change of the supply air pressure.

The spool valves utilized provided only a 50% duty cycle on the water port open or close cycle. However, suitable port and spool arrangements can be provided to achieve other duty cycles as desired. Other modifications are also feasible such as having the open port condition occur during the highest spool velocity and thus supply two pulses per spool cycle.

Perforated Piston Mechanical Pulse Generation. The device shown in Figures B-15 and B-16 was designed to manually generate a succession of discrete water slugs. The assembly consisted basically of two concentric tubes having a sliding fit. The inner tube carried a 1/16" nozzle on one end, and was provided with ten 1/8" diameter holes in the tube wall, all in line and equally spaced on 3/8" centers. The inner tube was keyed to the

~~CONFIDENTIAL~~

UNCLASSIFIED

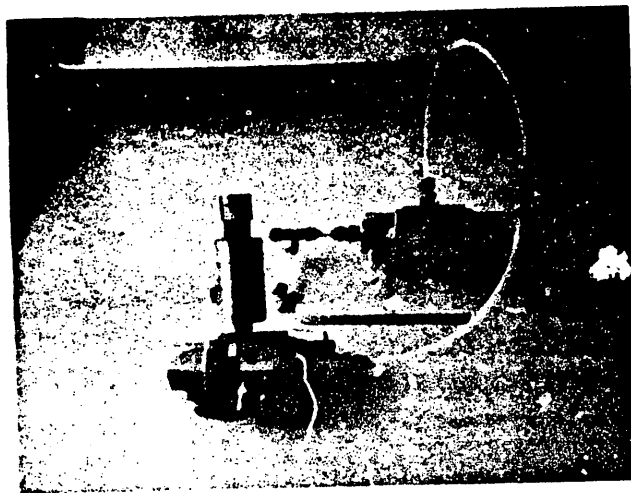
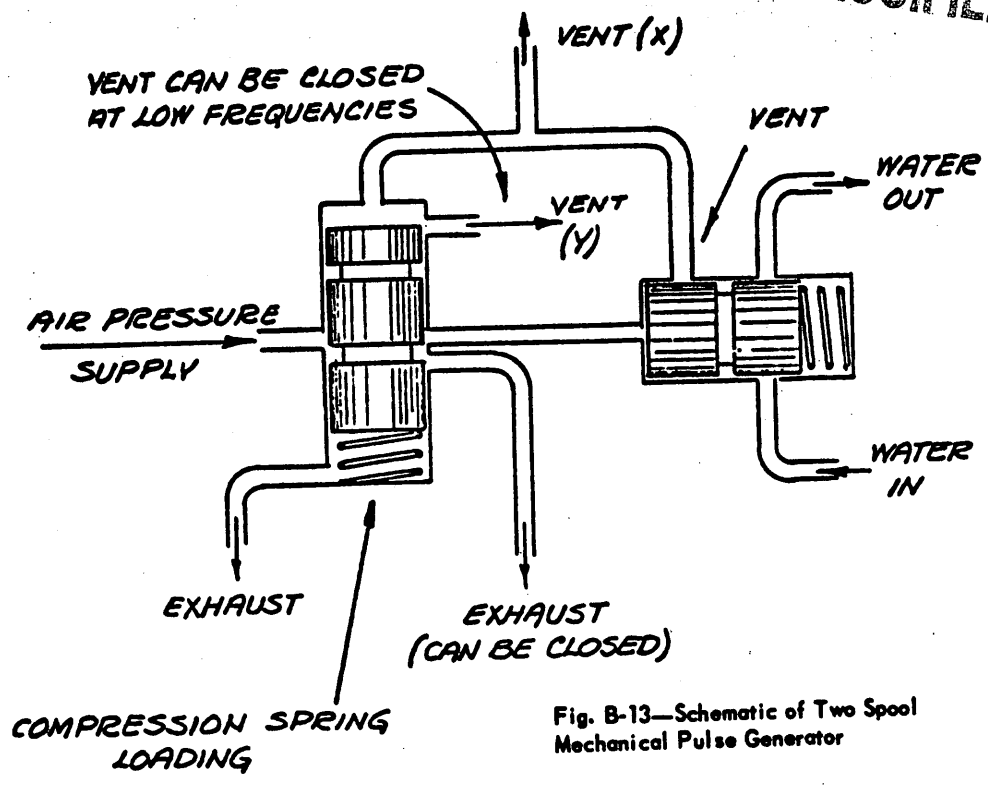

Fig. B-14—Photograph of Two Spool Mechanical Pulse Generator

UNCLASSIFIED

UNCLASSIFIED

~~CONFIDENTIAL~~

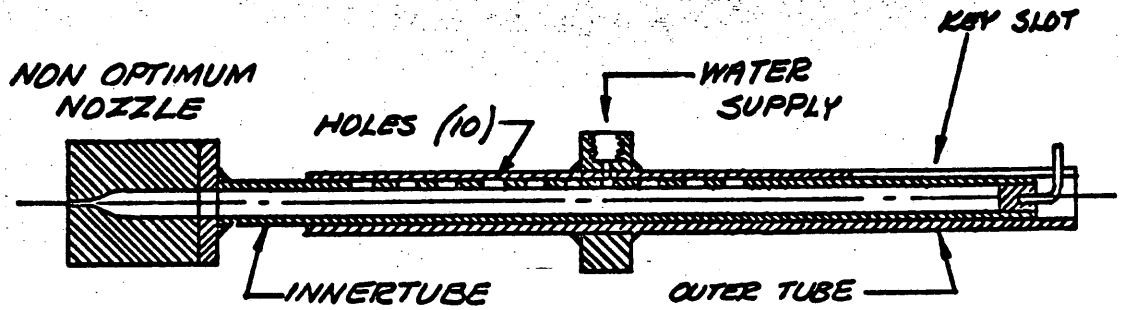

Fig. B-15—Perforated Piston Mechanical Pulse Generator Diagram

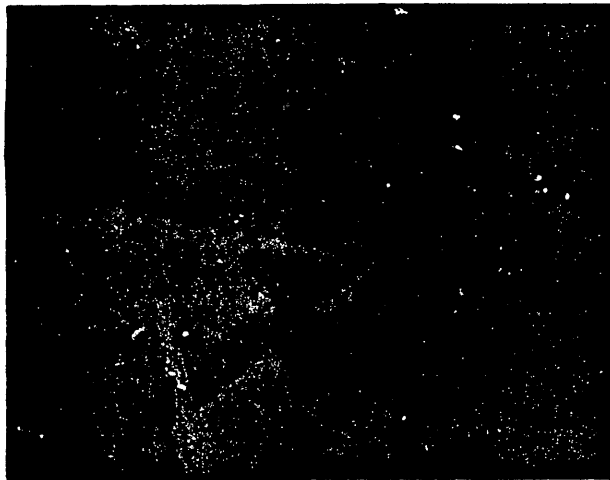

Fig. B-16—Perforated Piston Mechanical Pulse Generator Photo

~~CONFIDENTIAL~~

UNCLASSIFIED

UNCLASSIFIED

outer tube to preclude rotation of the inner tube as it moved in an axial direction. The ten holes in passing successively past a supply port in the outer stationary tube produced a series of water slugs. The assembly was tested at various water supply pressures ranging from 20 to 60 psig. Translation of the inner tube was manually imparted. The unit produced discrete water slugs (observed under stroboscopic lighting); however, in the crude form tested, it did not provide either well defined or uniform slugs. The latter was primarily attributed to the inability to manually produce uniform translation of the inner tube. Increased supply pressure increased the range of the water slugs but caused proportionate degradation of the water slug parcels. The nozzle utilized in these tests was not the final configuration but was a make-shift model which could be provided quickly. The objective of these tests was to examine a mechanical pulse generation technique.

An Embodiment

Figure B-17 illustrates one possible simple embodiment of the foregoing in a weapon. The perforated piston is used to provide a sequence of pulses.

Some of the design features not covered by the sketch are:

A mechanism to permit release of the pulses on an individual basis rather than as a train of pulses.

Means to insure that the nozzle will remain full of liquid until the first pulse is fired and between individual pulses.

Jet Interaction Pulse Generation

A jet can be clearly chopped into pulses by interaction of a second jet. This approach would allow initiation of jet motion within the weapon, release a jet slug, and cessation of jet motion within the weapon.

CONFIDENTIAL

UNCLASSIFIED

CONFIDENTIAL

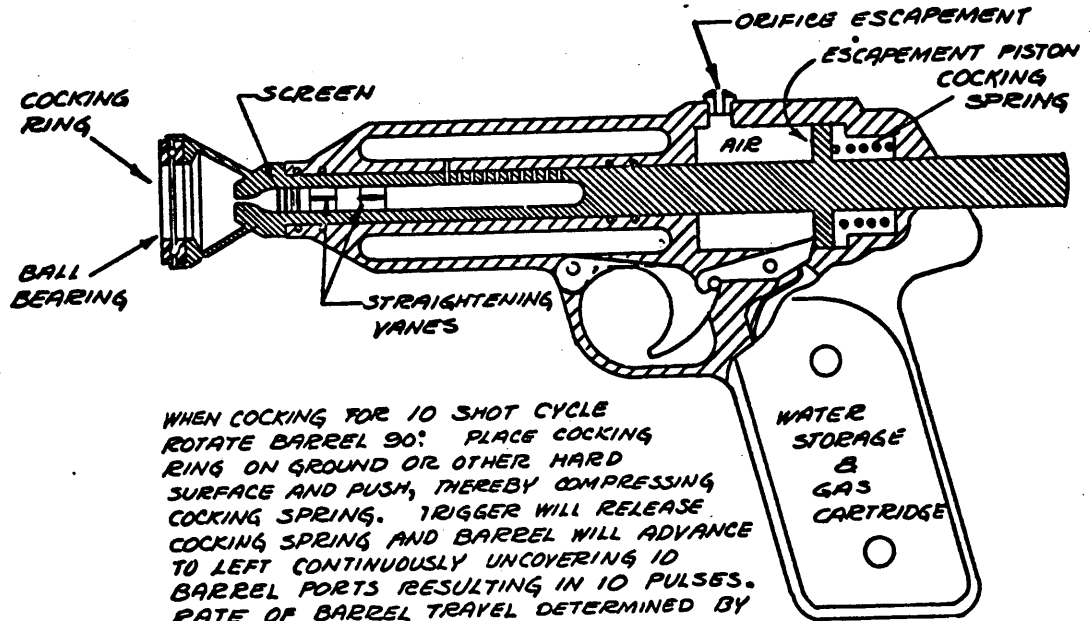

WHEN COCKING FOR 10 SHOT CYCLE
ROTATE BARREL 90°. PLACE COCKING
RING ON GROUND OR OTHER HARD
SURFACE AND PUSH, THEREBY COMPRESSING
COCKING SPRING. TRIGGER WILL RELEASE
COCKING SPRING AND BARREL WILL ADVANCE
TO LEFT CONTINUOUSLY UNCOVERING 10
BARREL PORTS RESULTING IN 10 PULSES.
RATE OF BARREL TRAVEL DETERMINED BY
SIZE OF ESCAPEMENT ORIFICE.

Fig. B-17—Squirt Gun

CONFIDENTIAL

UNCLASSIFIED

~~CONFIDENTIAL~~

UNCLASSIFIED

Figures B-18 through B-23 is a high speed motion picture sequence consisting of 44 frames. Frames 1 through 8 show initiation of the first jet. In frames 9 and through 16, one can observe growth of the blunt head of the slug as aerodynamic drag peels back the initial liquid front and it is overtaken by the following liquid. Frames 17 through 24 show initiation of the second jet which is directed from two o'clock towards the first jet. Frames 25 through 32 show the second jet approaching intersection with the first jet. Frames 33 through 40 show interruption of the first jet and the character of its trailing segment. There should be no dribble associated with such a shut-off system. Frames 41 through 44 show how completely this interruption can be maintained and the combined jets deflected into a catcher within the weapon for return to the charging chamber without leakage.

~~CONFIDENTIAL~~

UNCLASSIFIED

UNCLASSIFIED

CONFIDENTIAL

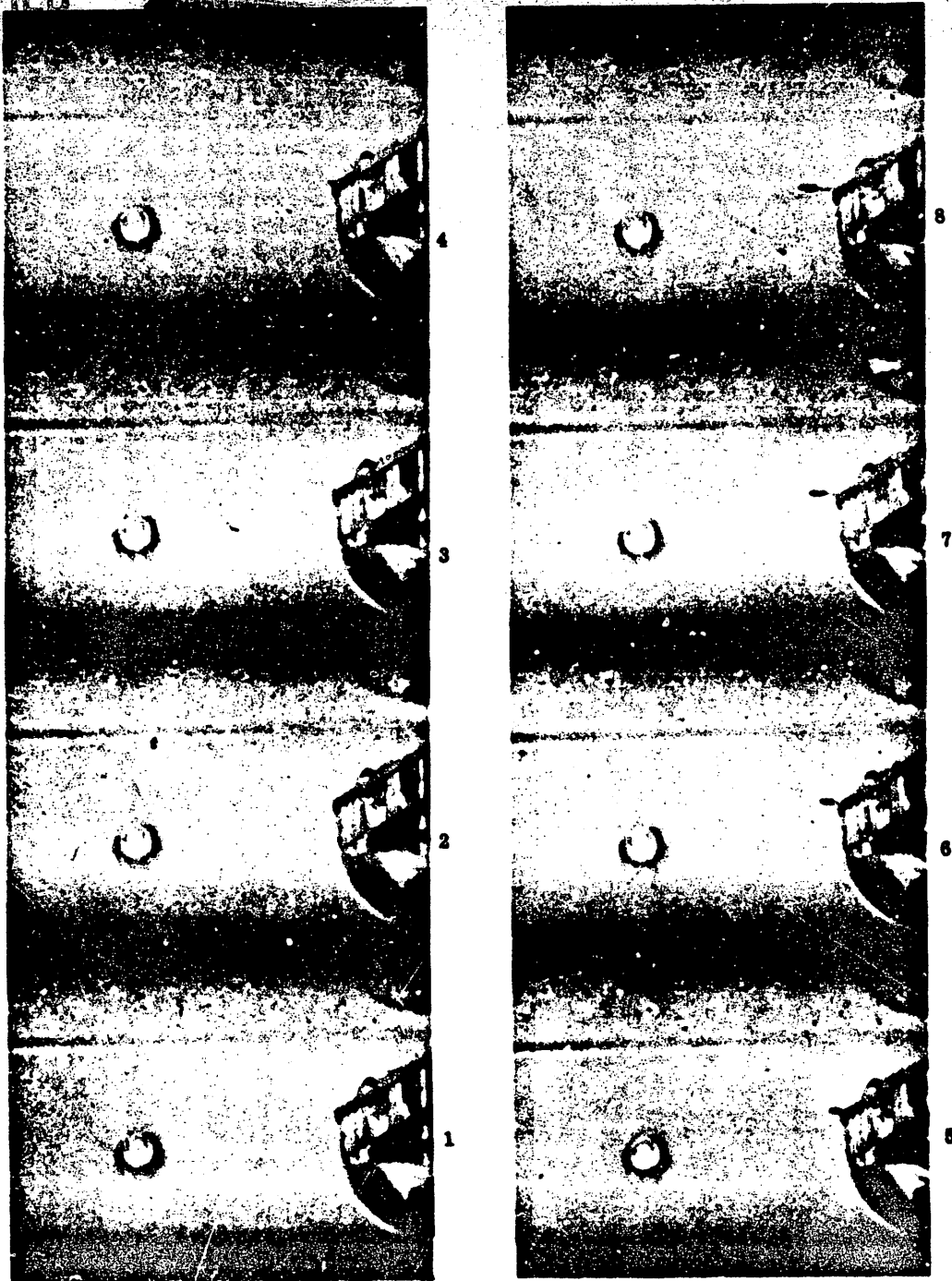

Fig. B-18

CONFIDENTIAL

UNCLASSIFIED

UNCLASSIFIED

~~CONFIDENTIAL~~

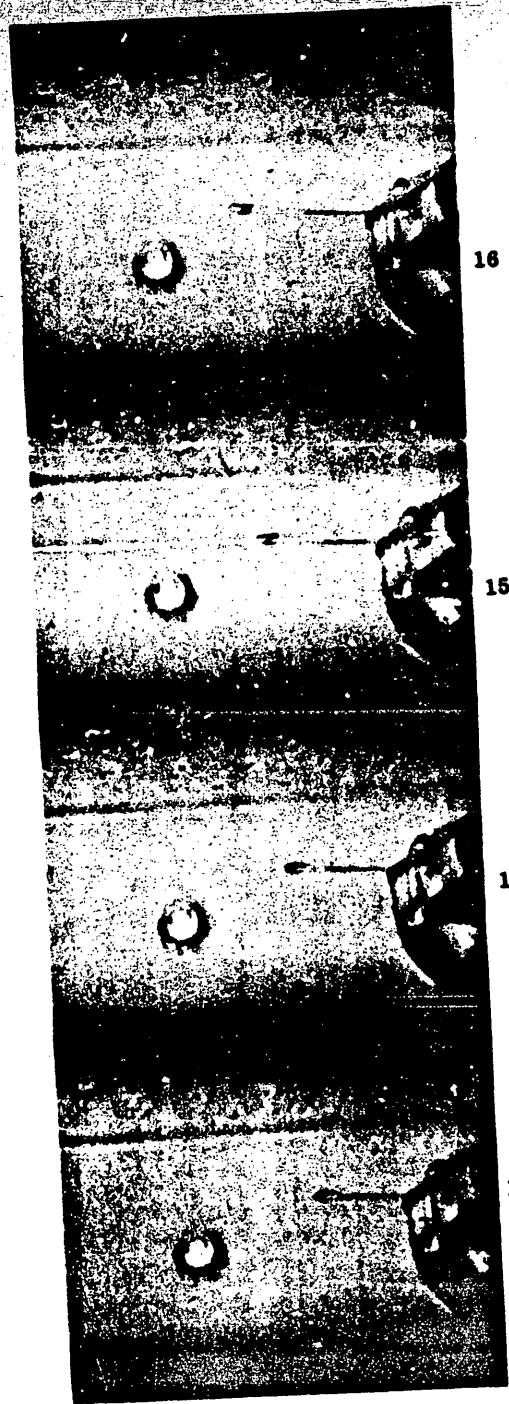
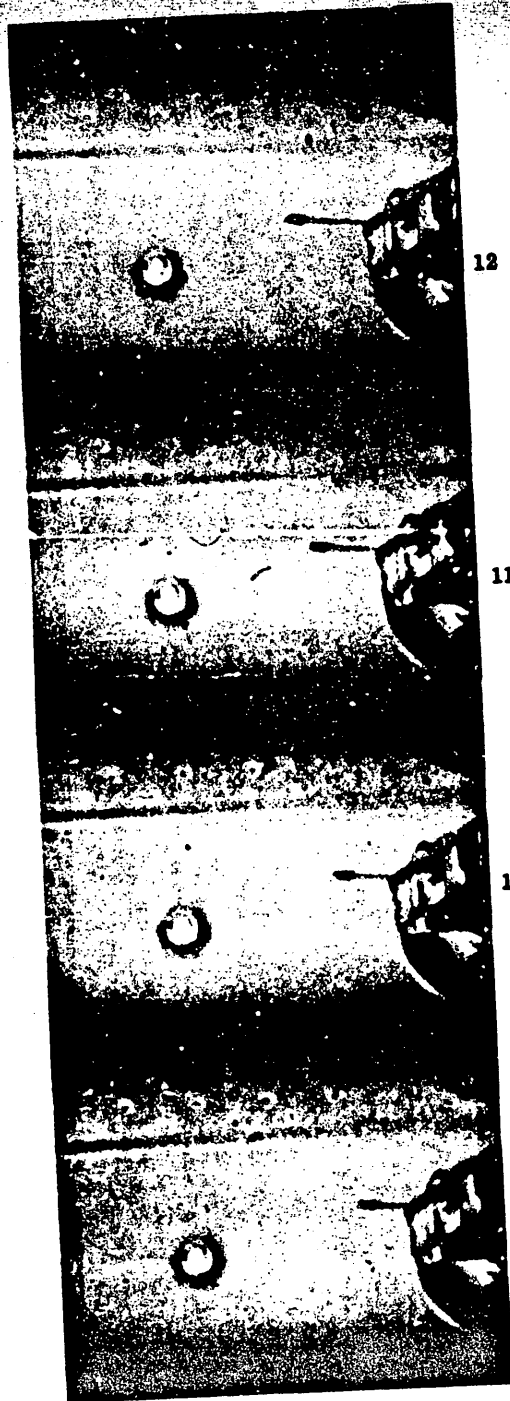

Fig. B-19

~~CONFIDENTIAL~~

UNCLASSIFIED

UNCLASSIFIED

CONFIDENTIAL

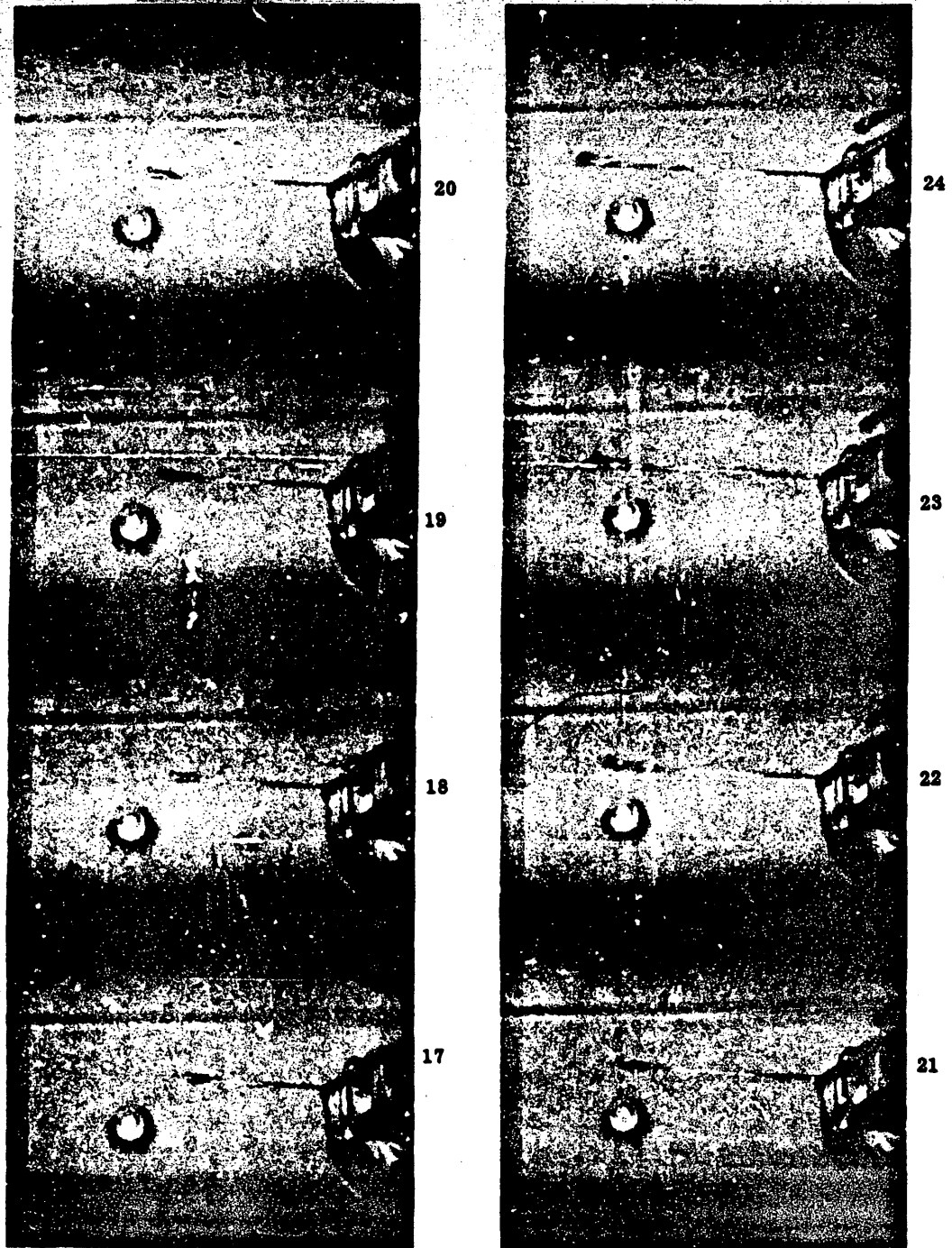

Fig. B-20

CONFIDENTIAL

UNCLASSIFIED

UNCLASSIFIED

~~CONFIDENTIAL~~

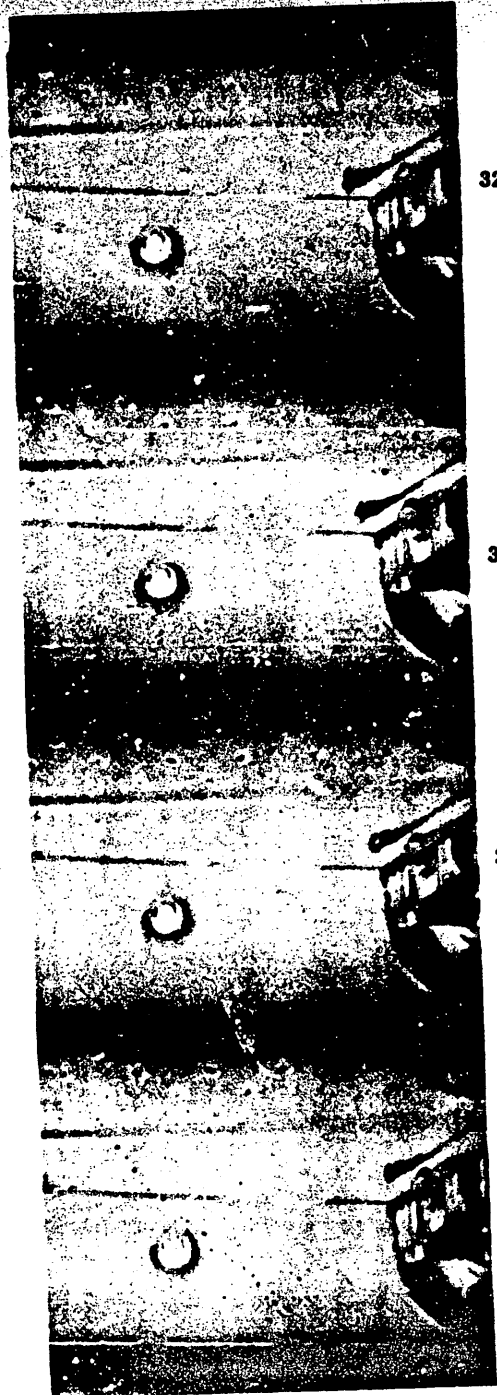
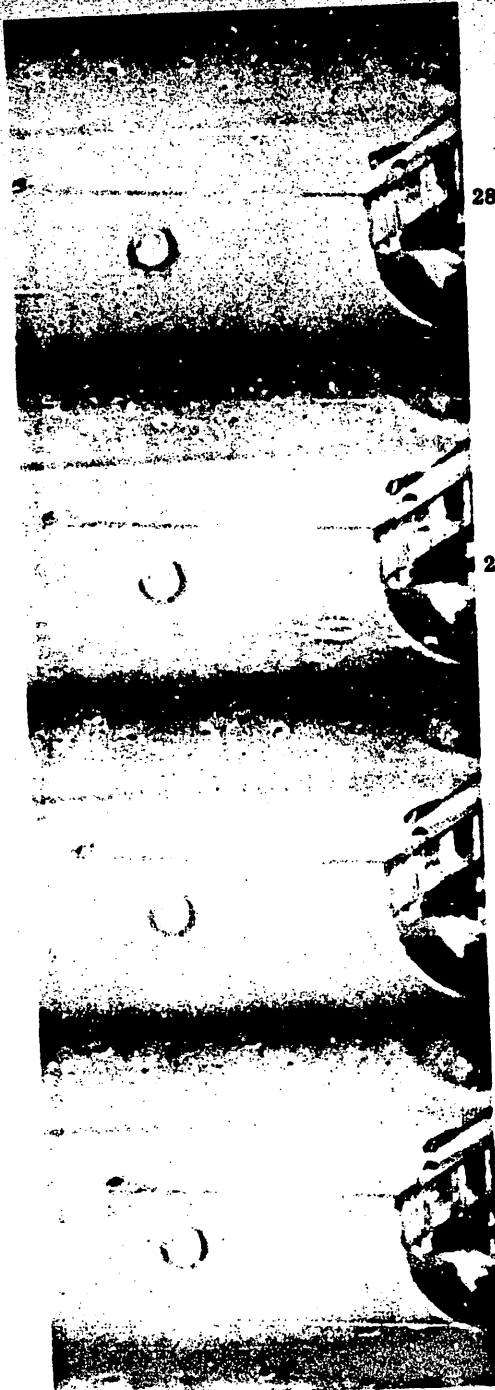

Fig. B-21

~~CONFIDENTIAL~~

UNCLASSIFIED

UNCLASSIFIED

~~CONFIDENTIAL~~

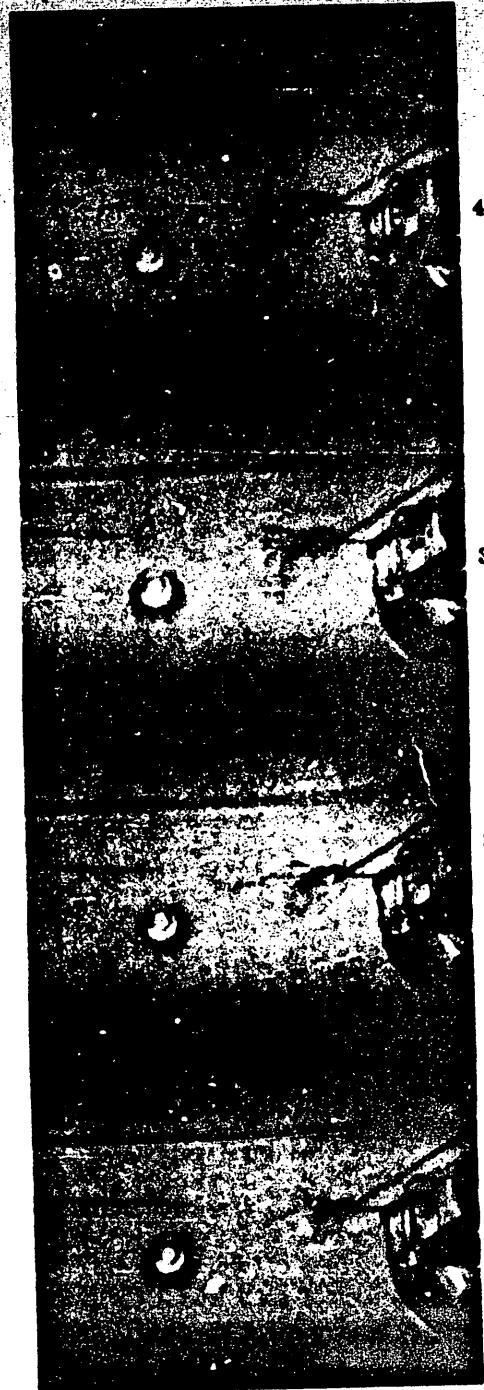
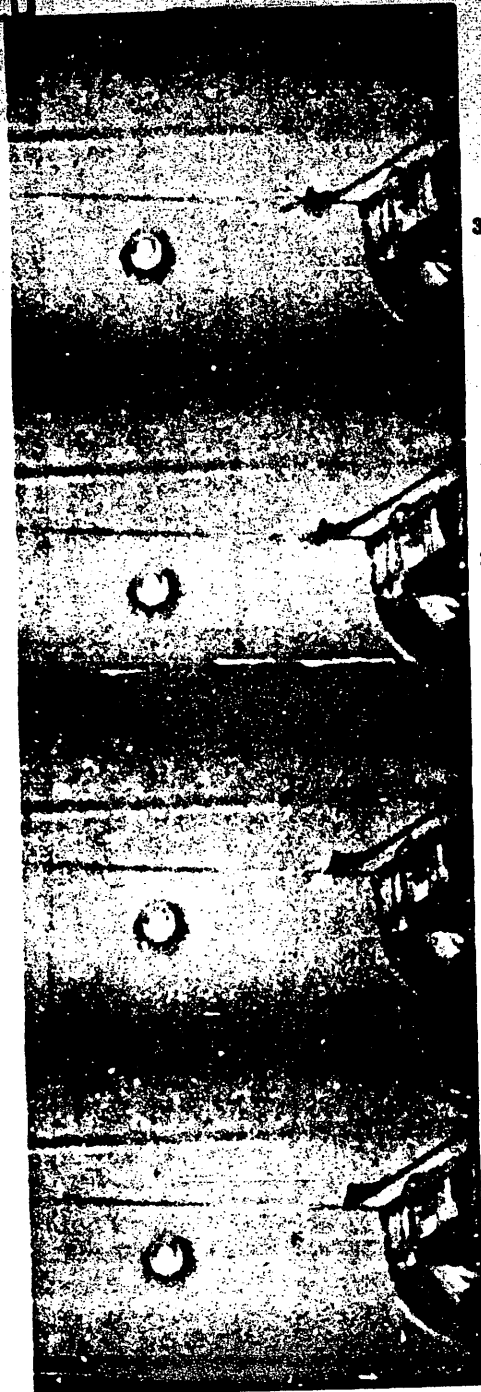

Fig. B-22

~~CONFIDENTIAL~~

UNCLASSIFIED

~~CONFIDENTIAL~~

UNCLASSIFIED



Fig. B-23

~~CONFIDENTIAL~~

UNCLASSIFIED

UNCLASSIFIED

~~CONFIDENTIAL~~

JET STABILITY

After careful review of the texts and reports available, it is clear that there is no universal agreement as to the exact mechanisms of jet instability.

The following summarizes the jet breakup process in a fashion that more or less presents a consensus of the various opinions.

Jet flow (liquid into air) arrives with some degree of residual turbulence. This turbulence can be considered to consist of two categories: jet body turbulence and surface turbulence. The wave length of this turbulence and the nature of the jet determine the degree of amplification of the disturbance. The amplification and frequency character are defined by the Orr - Sommerfeld equation..

If the disturbance is of a wave length that is amplified, then the most minute initial disturbance will eventually result in rough edges along the jet - air interface. These perturbations will grow until they are formed into spheres by the action of surface tension. At this time the jet becomes a segmented series of droplets travelling with high velocity.

The relative air velocity in the environment of these droplets presents a non-uniform flow profile. Just as a ping pong ball will be stabilized in an air jet, these droplets are scattered by the inverse air jet situation which they encounter upon moving away from the jet centerline through the entrained air into a regime of stagnant air. Basic air resistance theory has shown that air resistance or drag does not play a significant role until the jet stream becomes segmented.

All reports agree that the degree of initial turbulence is a parameter of the distance a jet can be projected before breakup.

From the Orr - Sommerfeld equation a domain can be plotted where a disturbance signal is amplified (see pp 389-390 etc. of Schlichting).

In jet flow, the δ can be taken as half the jet width.
 α is defined as $\frac{2\pi}{N}$ when N is the disturbance wave length.

~~CONFIDENTIAL~~

~~CONFIDENTIAL~~

UNCLASSIFIED

The nature of jet flow is such that there is an inflection point in the boundary velocity profile. This means that as the Reynolds Number increases toward ∞ , the unstable region is bounded (see Figure B-24). This is similar to the case of frictionless unstable flow. As a result, when the jet is operating at high Reynolds Numbers, the various effects are negligible and can be discounted. For the designs discussed, this is the case of $R_N = 10^5$.

Data on jets show that $N = 4.4d$ is amplified the most.

$$\lambda = \frac{2\pi}{a}$$

$$a = \frac{2\pi}{4.4d}$$

or if

$$\frac{d}{4} < \delta < \frac{d}{2} \quad (\text{The width of the estimate})$$

then

$$\frac{2\pi}{16} < a\delta < \frac{2\pi}{8.8}$$

$$.75 < a\delta < 1.5$$

which shows that to correlate with other data, the mixing boundary of a jet must be a small part of its diameter.

Data from neutral stability curves show that $a\delta$ gives the maximum amplification.

Thus, the range from $1/2 a\delta$ to $1-1/2 a\delta$ must be avoided and disturbance wavelengths from $8.8 d$ to $3 d$ must be avoided at the jet.

Disturbances originated within the nozzle or its approach section are distorted by passage through the nozzle. There is some controversy over the nature of this distortion. It would appear that disturbances in the direction of flow are stretched while disturbances normal to the flow are compressed in scale.

As this design utilizes an axially symmetric nozzle configuration, the inlet velocity component u_1 , and the outlet velocity component u_2 can be considered to be related by the areas so that

$$u_1 A_1 = u_2 A_2$$

$$u_1 d_1^2 = u_2 d_2^2$$

$$u_1 \left(\frac{d_1}{d_2}\right)^2 = u_2$$

~~CONFIDENTIAL~~

UNCLASSIFIED

UNCLASSIFIED

Thus, a disturbance at the upstream end of the nozzle will be stretched in scale by a factor $(\frac{d_1}{d_2})^2$ at the exit end of the nozzle.

In a single contraction of the nozzle design selected, the area ratio was approximately 8:1. Applying this to the dangerous critical wave lengths at the jet of 3 d to 9 d, the corresponding upstream critical wave lengths are 3.8 d to 9/8 d. In a double contraction nozzle of the type tested, the overall area ratio is 64:1 and the corresponding critical wave lengths are $\frac{3}{64}$ d to $\frac{9}{64}$ d.

For d = .137" the critical ranges are

- 3/8 d = .0514" simple contraction
- 9/8 d = .0154"
- 3/64 d = .0064" double contraction
- 9/64 d = .0019"

Unfortunately the only fine screen available not only had a solidity of .3 instead of the desired .2, but also had a wire size of .003" diameter which introduced disturbances which would be amplified in the jet. The mesh scale of .020" was outside of the critical regime. The jet nutation observed is therefore attributed to the fine screen which was used. A suitable screen can be fabricated but was not available within the time scale.

Conclusions

Screens and vanes must be used in conjunction with a good smooth nozzle design if one is to project the jet a maximum distance. However, every effort must be made to prevent eddy formation by these devices wherein the eddy size is within the critical wave lengths specified. Poor arrangements or sharp corners will lead to an increase of turbulence and jet instability.

A large contraction ratio permits low Reynolds Numbers at the screen and vane locations; however, it does not provide sufficiently low Reynolds Numbers to assure that no eddies will be formed, or that any eddies which are formed will be damped out. Therefore, one must design the flow straighteners and screens such that the perturbation formation diameter is such that it

~~CONFIDENTIAL~~

CONFIDENTIAL

UNCLASSIFIED

does not fall within the critical range of wave lengths. It is important to stress that a rough nozzle of good contour is much worse than a poorly designed nozzle which is very smooth. The surface finish of the order of 4 microinches is most appropriate for the problem at hand. Additional improvements can be achieved by tests incorporating the corrected screen design and an improvement in nozzle surface finish.

UNCLASSIFIED

~~CONFIDENTIAL~~

UNCLASSIFIED

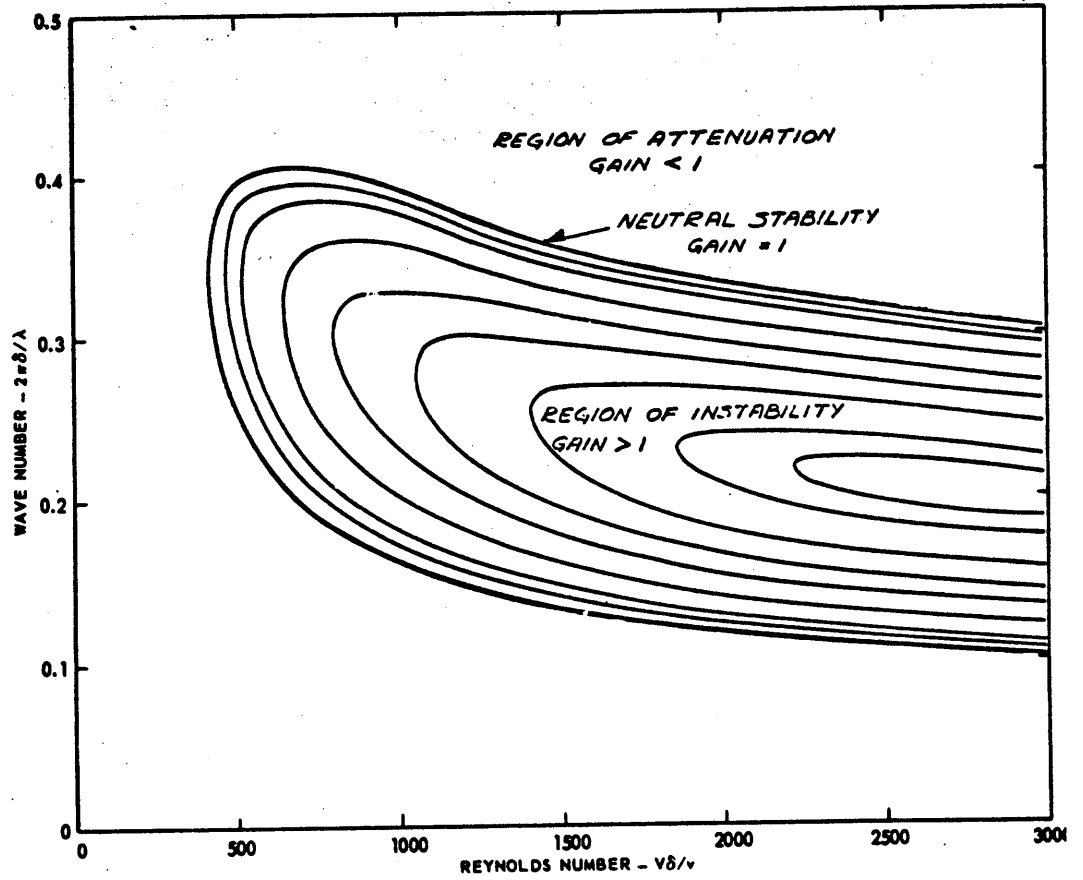

Fig. B-24—Orr-Sommerfeld Stability Characteristic

~~CONFIDENTIAL~~

UNCLASSIFIED

END

DATE
FILMED

3 - 82

DTIC

UNCLASSIFIED

CONFIDENTIAL

DEFENSE TECHNICAL INFORMATION CENTER
8725 Kingman Rd Ste 0944
Ft Belvoir, VA 22060-6218

OFFICIAL BUSINESS - PENALTY FOR PRIVATE USE \$300
POSTMASTER: DO NOT FORWARD

AD Number	Class	Pages	Type Copy	Source	Priority
C951256	C	69	H	F	

Received Date: 28-MAY-66

To : 7588
Req By : TERRY NOLAN

ATTENTION: D AMICK TECH LIB

ADVANCED RSCH PROJ AGCY

3701 N FAIRFAX DR
ARLINGTON, VA 22203-1714

374237001



UNCLASSIFIED

CONFIDENTIAL